



**dB PLUS II™**  
**Acoustic Deterrent System**

U.S. Patent No. 5,610,876  
Norwegian Patent No. 304001  
European Patent No. EP 0706 317 B1

# OWNER'S MANUAL

---

**AIRMAR**  
TECHNOLOGY CORPORATION

35 Meadowbrook Drive, Milford, New Hampshire 03055-4613, USA  
Tel: 603.673.9570 ▪ Fax: 603.673.4624 ▪ E-mail: sales@airmar.com

---

---

## Table of Contents

---

---

<b>Section</b>	<b>Page</b>
Airmar Technology Corporation .....	<b>1</b>
<b>dB Plus II™ System Overview</b> .....	<b>1</b>
<b>Installation</b> .....	<b>2</b>
System Layout .....	2
Projector Installation .....	3
Transmitter Installation .....	3
Power Supply System .....	4
Battery Charging .....	4
Battery Enclosure .....	4
<b>Operation</b> .....	<b>5</b>
Power-up .....	5
Normal Mode .....	5
Power Save Mode .....	5
Shutdown Mode .....	6
Fuse Protection .....	6
<b>Maintenance</b> .....	<b>6</b>
Batteries .....	6
Projectors .....	6
<b>Safety</b> .....	<b>7</b>
<b>Troubleshooting Problems</b> .....	<b>7</b>
Transmitter Inoperative .....	7
Projector(s) Not Pulsing .....	7
Reduced Sound Output. ....	7
<b>Specifications</b> .....	<b>8</b>
<b>Repair</b> .....	<b>8</b>
Cable .....	8
Transmitter .....	8
<b>Options, Parts and Accessories</b> .....	<b>9</b>
External Triggering Capability .....	9
Parts and Accessories .....	9
<b>Airmar Limited Warranty</b> .....	<b>10</b>
Limited Warranty .....	10
Warranty Return Procedure .....	10
Limitation of Remedies .....	10
<b>dB Plus II™ Registration Form</b> .....	<b>11</b>

---

---

## **AIRMAR Technology Corporation**

---

---

To our customers:

Thank you for purchasing Airmar Technology Corporation's dB PLUS II™ Acoustic Deterrent System. Since its founding in 1981, Airmar has been a leader in product innovation and technical excellence. Our position as a world-class manufacturer is evidenced by the many U.S. and foreign patents we hold.

You have chosen a product with a proven performance record of reliability and quality, and we are confident you will be satisfied with it. This manual provides important information regarding its operation and maintenance. To achieve optimal performance, it is important that you familiarize yourself with its content.

Installation of your dB PLUS II™ system should be performed by a factory authorized technician who will determine the best layout of equipment based on a site assessment. The proper placement of the sound projectors is necessary to ensure maximum protection from predators.

A reliable power source is of crucial importance to the effectiveness of the product, especially when it must be installed away from shore power. Care should be taken to ensure proper installation and maintenance of your power supply in accordance with the manufacturer's instructions.

Airmar has made product safety a priority in the design of the dB PLUS II™ system. Proper operation, using the safety features, should ensure the protection of both humans and marine mammals.

Airmar Technology Corporation backs the dB PLUS II™ equipment with a one year warranty against defects in workmanship. However, we cannot guarantee that the system will completely eliminate attacks, such as those from hearing impaired seals. Hearing loss, occurring in a small portion of marine mammals, can be attributed to interactions with fisheries using "seal bombs" and parasites known to effect the hearing of older marine mammals. Airmar recommends using the dB PLUS II™ system in conjunction with other predator control methods.

Welcome to the Airmar family of satisfied customers!

---

---

## **dB Plus II™ System Overview**

---

---

The dB PLUS II™ Acoustic Deterrent System provides up to 3,000 square meters of protection. Four projectors<sup>1</sup>, operating from one, four circuit, DC powered transmitter, provide high intensity acoustic pulses that cause significant discomfort to seals in the guarded area. However, these pulses have no known effect on fish since the system's frequency of operation is well above their hearing range.

The rugged dB PLUS II™ equipment is designed to withstand the harsh conditions of the marine environment. This feature-rich system includes low-power warning alarms as well as an array of safety enhancements.

To protect both divers and marine mammals, it is equipped with a unique Soft-start™ feature which allows time to clear the area before reaching full sound output. As further protection for divers, the transmitter power switch is designed to be locked in the "OFF" position to prevent accidental activation, and the high-visibility cover can be drawn over the transmitter box to signify a diver's presence in the water.

Development of the dB PLUS II™ Acoustic Deterrent System has involved extensive field tests conducted over an extended period of time. It is the most advanced system available today.

---

1. Projector and transducer are synonymous terms in this document.

---

---

## Installation

---

---

After the installation of your dB Plus II™ system by a trained authorized technician, please familiarize yourself with the following principles of installation, operation, and maintenance. This system has been custom engineered and carefully installed at your facility. Should it be necessary to move equipment, including relocating any of the projectors, it is recommended that the move be done by an authorized technician for best results.

### System Layout

At fish farms with square pens, Airmar recommends placing the batteries, charging devices, and transmitter in the center of the set of pens thus allowing the projectors to be located close to the outer corners (see Figure 1). However, if a sheltered location is available for the batteries, charging devices, and transmitter, it should be used.

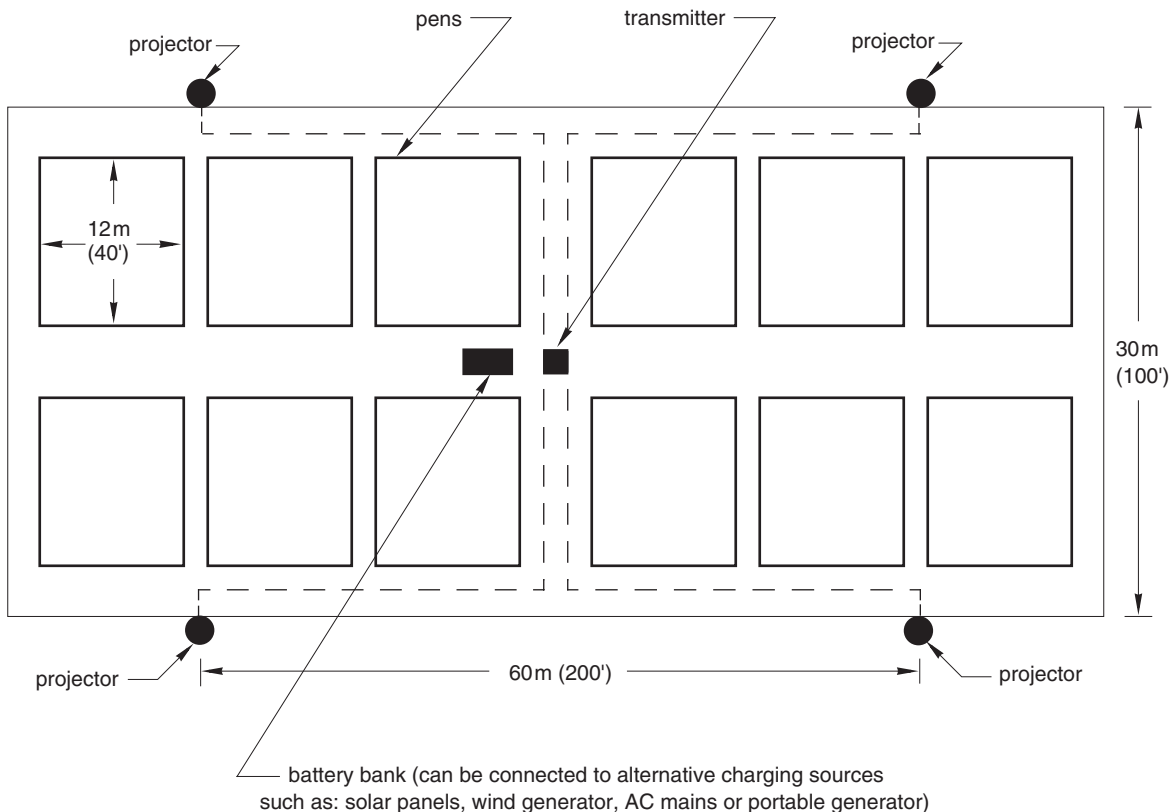

Figure 1. Recommended system layout for typical square pen configuration  
(Layout will vary with different pen styles)

The dB Plus II™ system is designed to emit high intensity acoustic pulses from each of its four underwater projectors resulting in significant discomfort to most seals. Sound pressure drops dramatically with increased distance from the projector, so proper projector layout is *imperative*.

Since the placement of the projectors is the key to the success of the dB Plus II™ system, they must be positioned so that the sound patterns overlap. The closer the spacing between the projectors, the higher the intensity of the sound field, and therefore the greater the protection from predators. Using the 60m (200') long projector cables provided, will result in the maximum recommended spacing between projectors at a fish farm with the above pen layout. For protection from seals, the distance between projectors should never exceed 60m (200').

The effective range of the projectors is reduced by underwater obstructions such as fouled nets or the biomass of a school of fish. Therefore, it is necessary to completely surround the entire pen system and, in effect, create an acoustic barrier around the outer perimeter (see Figure 2). The range of each projector limits the coverage of a complete 4 projector system to an area not exceeding 3,000 square meters (33,000 sq. ft.).

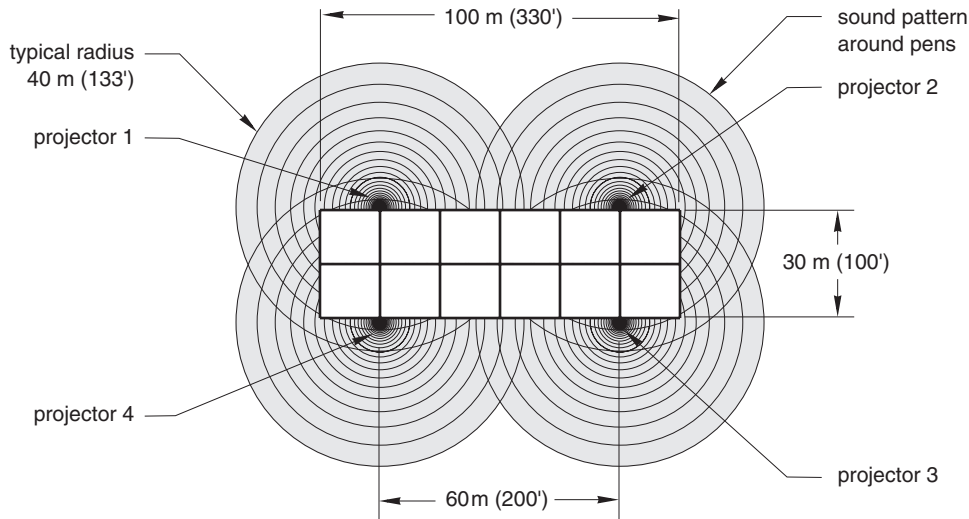

Figure 2. Projector coverage

### Projector Installation

The standard dB Plus II™ system has four underwater sound projectors. Each projector has 60 m (200') of high visibility, abrasion resistant cable with a corrosion resistant, weatherproof connector. It should be noted that the projector connectors and the power supply connectors are of reverse gender to prevent incorrect installation. The projectors are positioned at the outer edge of the pen walkways but not in the path of boat traffic and propellers. If the transmitter has been placed away from the center of the installation, it may have been necessary to add extension cables to the projector cables. Airmar's unique design allows adding extensions with very little loss of sound output.

Whenever possible, projector cables should be laid underneath walkways. Areas prone to moving and swaying, such as gangplanks, should be avoided, as they could chafe or cut the cable.

Each projector is equipped with an eyelet to allow it to be suspended from a line approximately 1 m (3') below the bottom of the pen. **Do not** suspend a projector by its power cable since this may sever internal connections. Below the waterline, the cable must be tie-wrapped to the supporting line and free of any slack or loops. Each projector should be suspended at the outer most edge of the walkway in order to avoid fouling with other lines or netting. **Never** suspend a projector between or inside pens.

### Transmitter Installation

The transmitter must be mounted at least 1 m (3') above any decking and, preferably, protected from the rain. Placing it directly under solar panels is ideal. Although the transmitter is waterproof, this added protection will prolong its life.



**WARNING:** Under no circumstances, should unauthorized personnel remove the transmitter cover. Doing so may result in electrical shock. Unauthorized removal of the transmitter cover breaks the factory seal and voids the warranty.

## Power Supply System

The dB Plus II™ system requires 24VDC, supplied by lead acid batteries, to provide adequate power surge levels during sound transmission and a temporary reserve of power for times when the batteries cannot be recharged. Power inverters are unable to meet this requirement and are not recommended.

- **Shore Power**—At locations where shore power is available, AC mains, two 12V batteries and a battery charger(s) is advised.
- **Batteries**—At sites where shore power is not available, a system of four 6V deep cycle batteries is recommended (see Figure 3). Four 6V batteries connected in series provides much more reserve capacity than two 12V batteries. Deep cycle batteries are necessary because they can withstand the many charge and discharge cycles which occur when operating the dB Plus II™ system. Consult your power supply manual for proper installation and maintenance of the power supply equipment.

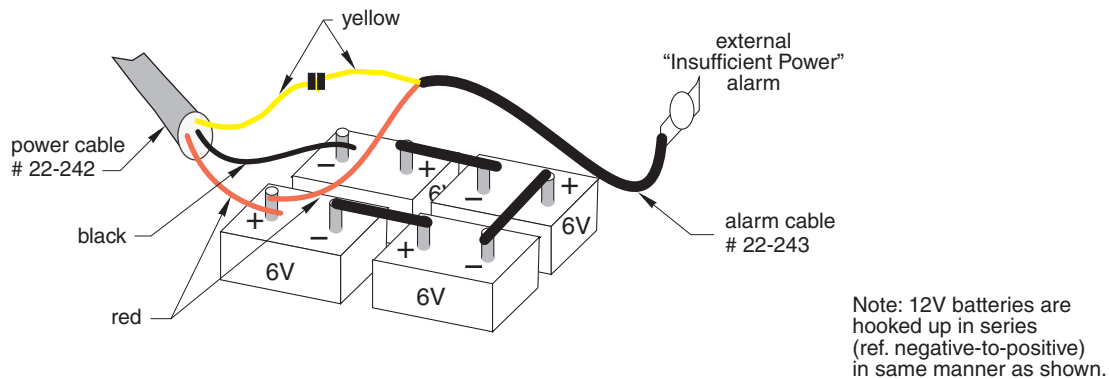

Figure 3. Power supply cable hookup

The condition of the batteries must be checked **daily**, regardless of the type of charging system used. The voltage level must never drop below 24V, and electrolyte levels must be maintained in accordance with the manufacturer's instructions. Terminal connections must be kept tight and free of corrosion.

## Battery Charging

- **Solar panels**—Depending on the climate, a four module regulated solar panel array may be adequate.
- **Wind generators**—In windy locations, regulated 24V wind generators offer an alternative means of charging the batteries.
- **Solar and wind**—Weather conditions effect the performance of both solar panels and wind generators. A charging system that combines both may provide a reliable charging source since one of these conditions is present on most days.
- **Portable generator**—Use of an engine powered generator with a battery charger is much less desirable. Manual charging must be done often enough to keep the batteries above 24V. However, a portable generator could be used as a backup to solar or wind systems.

Any charging method may have difficulty meeting the power demand. Two sets of batteries that can be rotated is recommended. While one set is in use, the alternate batteries can be fully charged.

## Battery Enclosure

The batteries should be protected in a weatherproof structure. A wooden enclosure with venting and drainage holes is very effective, causing less condensation than one made of plastic or fiberglass. In locations where the temperature drops below freezing, rigid foam insulation on the inside is highly recommended.

---

---

## Operation

---

---

### Power-up

Before activating the system, scan the area around the pens for the presence of divers in the water. When the area is clear of divers, turn the power switch to the “ON” position. Note that the projectors will start transmitting at 20% of power and take approximately 70 seconds to reach 100% power. This unique Soft-start™ safety feature allows both divers and marine mammals time to swim a safe distance away from the projectors thus avoiding the possibility of hearing damage.



**WARNING:** Before a diver enters the water within 150 m (500') of a dB Plus II™ system, **always turn the power switch to “OFF” and secure it in the “OFF” position with the locking pin attached to the diver’s cover (see Figure 4). In addition, the high visibility diver’s cover must be securely fastened over the transmitter, signaling the presence of a diver in the water. The pin and cover shall remain in place until the area is clear of divers.**

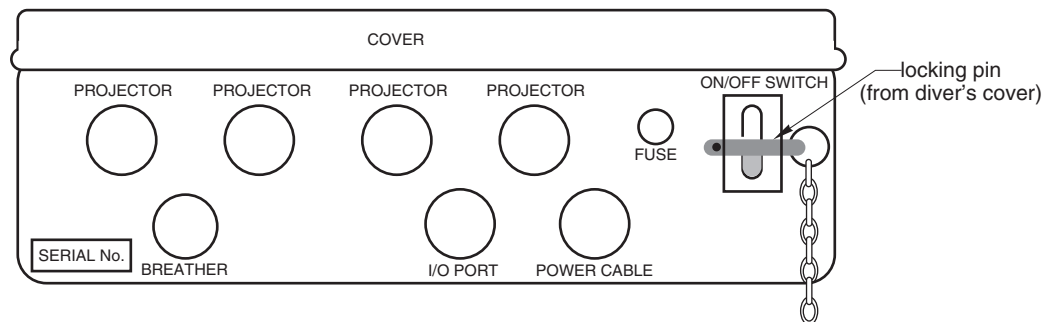

Figure 4. Bottom view of transmitter

### Normal Mode

The transmitter operates in the *normal mode* when the battery voltage is above 22VDC. It pulses each projector sequentially for 2.5 seconds with a 2 second off period between transmissions. The total cycle takes 18 seconds for all four projectors to transmit. The green light on the front panel of the transmitter indicates *normal mode* when it is illuminated (see Figure 5).

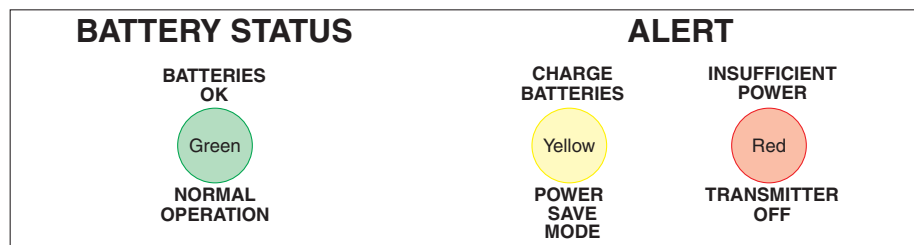

Figure 5. Transmitter panel

### Power Save Mode

When the battery voltage drops below 22VDC, the transmitter will automatically switch to the *power save mode*. This extends the off period between projector pulses to 6.5 seconds. Power consumption is cut by 50% while maintaining close to full sound output from the projectors. The total cycle time for all four projectors to transmit extends to 36 seconds. When the yellow and red lights alternately illuminate on the transmitter and the “Insufficient Power” alarm sounds, the *power save mode* is active indicating that the batteries need recharging (see Figure 5).

**Caution:** Do not run the system in the power save mode for an extended period of time. This will result in less than optimal protection from predators. This feature is designed to allow for temporary coverage until the batteries are recharged.

## Shutdown Mode

Whenever the battery voltage drops below 20VDC, the transmitter will automatically switch to the *shutdown* mode. The red light on the front panel will flash to signal that the transmitter is off and that the battery voltage is below the level needed to power the transmitter (see Figure 5). When in the *shutdown* mode, recharge the batteries as soon as possible to minimize exposure to marine mammal attacks.

**Caution:** *The importance of properly maintaining and charging the batteries cannot be stressed enough. The dB Plus II™ system will not operate as designed unless the power supply is adequate. It is highly recommended that you develop a program of daily battery monitoring and maintenance.*

## Fuse Protection

The dB Plus II™ transmitter is protected by a 8 amp AG fuse. If the power cable leads are mistakenly reversed or the transmitter is inoperative, check for a blown fuse. The fuse is located in a drip-proof holder on the bottom panel of the transmitter (see Figure 4).

---

---

# Maintenance

---

---

## Batteries

**The condition of the batteries must be monitored daily.** The voltage level should not drop below 24VDC and electrolyte levels must be maintained in accordance with the manufacturer's instructions. Keep battery terminal connections tight and free of corrosion.

## Projectors

To maintain the projectors, they must be removed from the water every month and inspected for marine growth, chaffing of the cable and wear of the support line. Any growth on the projector's acoustic window will block the sound generated severely reducing its effectiveness (see Figure 6).

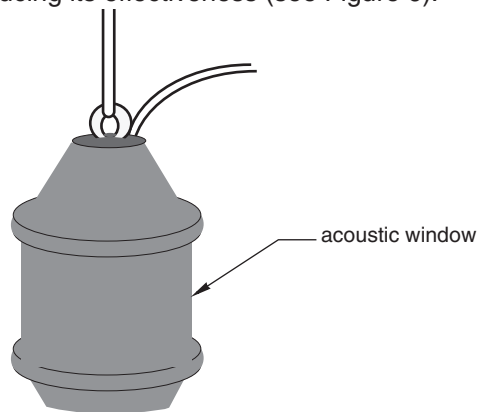

Figure 6. Projector

**Caution:** *Always switch the transmitter to "OFF" before removing a projector from the water. The projector is designed to transmit in water only; transmitting in air may cause damage.*

To clean a projector, gently scrape growth from its surface using a stiff brush or putty knife. Remove any remaining growth with a "scotch pad" and water. **Never use solvents.** Strong solvents, such as acetone, attack many polymers and dramatically reduce their strength leading to internal leaks and projector failure. Clean with a soft cloth and mild household detergent.

---

---

## Safety

---

---

Always comply with the safety precautions. The following warnings are posted on the front panel of the transmitter.

**DANGER:** Temporary or permanent hearing loss may result from underwater exposure to high intensity sound generated by this equipment. This transmitter's "ON-OFF" switch must be locked in the "OFF" position whenever a person is underwater and within 150 meters (500') of a transducer.

**NOTICE TO DIVERS:** This transmitter's "ON-OFF" switch must be locked in the "OFF" position and the diver's safety cover put in place over the transmitter box before entering the water. If the system is switched on accidentally, immediately surface at the normal ascent rate.

---

---

## Troubleshooting Problems

---

---



**WARNING:** Always lock the system in the "OFF" position before troubleshooting to avoid electrical shock and damage to the projector(s).

### Transmitter Inoperative

- Check the power supply voltage; batteries must be charged to at least 20V. Recharge the batteries.
- Check battery terminals for corrosion. Clean the terminals if necessary.
- Check for loose or corroded power cable ends at the batteries. Clean or tighten the cable ends.
- Check for a blown transmitter fuse. Replace the blown fuse with a new 8A fuse (see Figure 4).
- Check for a loose or disconnected power cable connector. Secure the connector.



**WARNING:** Under no circumstances should unauthorized personnel remove the transmitter cover. Doing so may result in electrical shock. Unauthorized removal of the transmitter cover breaks the factory seal and voids the warranty.

### Projector(s) Not Pulsing

- Check for loose or disconnected projector connectors. Secure the connector.
- Check the inoperative projector(s) cable(s) for cuts or kinks. Have damaged cable(s) repaired by a factory trained technician or use the Airmar Splice Kit #33-045.

### Reduced Sound Output.

- Check the power supply voltage; batteries must be charged to at least 20V. Recharge the batteries.
- Check each projector for fouling. Clean the projector's acoustic window (see Maintenance, page 6).
- Check for underwater obstructions that might be blocking the projector(s). Remove the obstructions or reposition the projector(s).

---

---

## Specifications

---

---

- Coverage for aquaculture application: up to 3,000 square meters.  
(This may vary according to location, target species, and pen configuration.)
- Standard cable length: 60m (200')
- Projector transmit source level: 198dB re 1 micropascal at 1 m RMS
- Projector impedance: 100 ohms
- Transmitter: 4 channels with individual fuses
- Transmitter pulse power: 1.8kW RMS per channel
- Supply voltage:

Nominal	24 VDC
<i>Normal mode</i>	22 VDC minimum - 30 VDC maximum
<i>Power Save mode</i>	20 VDC minimum - 22 VDC maximum
<i>Shutdown mode</i>	0 VDC minimum - 20 VDC maximum
- Power consumption: 1.7 A equivalent continuous current draw in *Normal mode*  
0.9 A in *Power Save mode* (factory preset to use 50% less power)
- Soft-start™: 70 seconds to go from 20% to full power
- Audible “Insufficient Power” alarm: 97 dB

*Note: Design and specifications are subject to change without notice.*

---

---

## Repair

---

---

### **Cable**

Repairs to cut or damaged cables can be made using an Airmar Splice Kit #33-045, which includes simple to follow instructions. This kit can be obtained through your local distributor.

### **Transmitter**

All transmitter repairs must be performed by factory trained specialists. If you experience a problem with the dB Plus II™ transmitter or have questions about its operation, please call your local distributor or Airmar Technology Corp. at (603) 673-9570. Please have the transmitter serial number (located on the bottom of the transmitter) available at the time of the call.

---

---

## Options, Parts, and Accessories

---

---

### External Triggering Capability

The transmitter has a connector (I/O) port for a remote switch that can be activated by a mammal detection device or a pen monitoring system (see Figure 2). Remote activation makes it possible to transmit only when marine mammals are detected.

### Parts and Accessories

Description	Airmar Part Number
Power cable	22-242
Alarm cable	22-243
Alarm and cable assembly	20-151
“Insufficient Power” alarm	07-182
Projector	42-006
Projector (transducer) cable	06-041
Splice kit	33-045
Printed Circuit Board	25-067
Diver’s cover and pin	20-147

---

---

## **AIRMAR® Limited Warranty**

---

---

Airmar Technology Corporation warrants its dB Plus II™ Acoustic Deterrent System to conform to the specifications listed. Airmar will repair, replace or issue credit for any product proven to be defective by Airmar under normal use at no charge for a period of 12 months from date of installation, except as provided below.

### **Limited Warranty**

Where Airmar Technology Corporation has issued electrical and mechanical design specifications pertaining to acoustic deterrent products, then those specifications are the sole basis for product acceptability.

Warranty claims pertaining to damage incurred during shipment must be made in writing to Airmar within 15 days of the invoice date.

Airmar Technology Corporation assumes no responsibility for damage incurred during installation by unauthorized personnel.

The Airmar Technology Corp. warranty does not apply to any acoustic deterrent product that has had the transmitter cover removed thus breaking the cover seal.

The Airmar Technology Corporation warranty does not apply to products which have been subjected to: impact; abuse; pinched, cut or abraded cables; contact with strong solvents; misuse; improper mounting; or operated with improper fuses or incorrect electrical connections.

The Airmar Technology Corporation warranty does not apply if the system part number, serial number or date code have been removed, altered or rendered illegible.

Costs associated with product replacement (travel, customs duties and reinstallation labor) are specifically excluded on all products.

THE WARRANTIES BY AIRMAR TECHNOLOGY CORPORATION ARE STRICTLY LIMITED TO THE TERMS INDICATED HEREIN, TO THE EXPRESS WARRANTIES STATED HEREIN AND FOR THE PERIODS STATED HEREIN. THERE ARE NO IMPLIED WARRANTIES OF MERCHANTABILITY OR WARRANTIES OF FITNESS FOR A PARTICULAR PURPOSE OR ANY OTHER EXPRESS OR IMPLIED WARRANTIES.

### **Warranty Return Procedure**

In returning any products which the buyer regards as defective, the buyer must state the product(s) to be returned and receive a Returned Materials Authorization (RMA) number from Airmar prior to returning the products. Upon receipt of the returned products, Airmar, at its election, will repair, replace, or issue credit within 30 days after receipt at Airmar of returned products. Transportation charges to Airmar on warranty returns must be prepaid by the customer. Return surface transportation charges will be prepaid by Airmar.

Airmar will inform the buyer in writing of any warranty claims disallowed and the reasons for disallowance. Products returned to Airmar for a warranty claim, and not of Airmar manufacture, are subject to a handling fee.

### **Limitation of Remedies**

The remedies provided in this limited warranty are the exclusive remedies available for defective equipment. Airmar Technology Corporation shall not be liable for any incidental or consequential damages relating to the sale of this equipment. Under no circumstances shall Airmar Technology Corporation's liability in connection with the sale of equipment exceed the price paid for the equipment.

**AIRMAR**  
TECHNOLOGY CORPORATION

35 Meadowbrook Drive, Milford, New Hampshire 03055-4613, USA  
Tel (603) 673-9570 ▪ Fax (603) 673-4624 ▪ E-mail sales@airmar.com

