

OWNER'S GUIDE & INSTALLATION INSTRUCTIONS

Movable, Fan-beam Transducer

with Transom Fitting and Trolling Motor Fitting

Model P48W

Patent Pending

12/14/10

17-499-01 rev. 04

WARNING: Always wear safety goggles and a dust mask when installing to avoid personal injury.

CAUTION: Operate at 200kHz only. Operating at any other frequency will permanently damage the transducer and/or the echosounder.

CAUTION: Never use solvents. Cleaners, fuel, sealants, paint, and other products may contain strong solvents, such as acetone, which attack many plastics, greatly reducing their strength.

IMPORTANT: Read the instructions completely before proceeding with the installation. These instructions supersede any other instructions in your instrument manual if they differ.

Applications

- Recommended for boat up to 7 m (22') long
- Not recommended for boats with large inboard engine(s)
- Not recommended for stepped transoms, as transducer will be difficult to adjust.
- Vertically orients sound beam on hull with deadrise angle up to 22°
- Adjusts to transom angles from 2° – 22°
- Requires 89 mm (3-1/2") of headroom to install
- Bracket protects sensor from frontal impact only
- Trolling motor fitting adapts transducer for use with a trolling motor or optional Portable Mount Kit

Tools & Materials

Safety goggles

Dust mask

Phillips screwdrivers

Pencil

Electric drill

Drill bits:

Bracket holes 4 mm, #23, or 9/64"

Transom hole (optional) 18 mm, 11/16", or 3/4"

24 mm or 15/16" or 1" (Raymarine only)

Cable clamp holes 3 mm or 1/8"

Masking tape

Angle finder (some installations)

Marine sealant (suitable for below waterline)

Straight edge

Grommets (some installations)

Cable ties (some installations)

Band clamp (trolling motor mount)

Measure before purchasing (see Figure 9)

Water-based anti-fouling paint (**mandatory in salt water**)

Record the information found on the cable tag for future reference.

Part No. _____ Date _____ Frequency _____ kHz

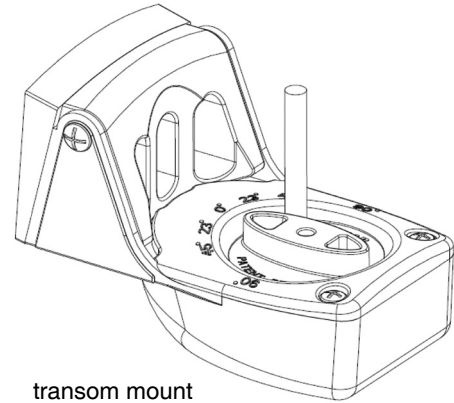

transom mount

Transom Mount

Mounting Location

CAUTION: Do not mount in an area of turbulence or bubbles: near water intake or discharge opening; behind strakes, struts, fittings, or hull irregularities

CAUTION: Avoid mounting the sensor where the boat may be supported during trailering, launching, hauling, or storage.

- For the best performance, the transducer's face must be in contact with smooth water. To identify an area of "clean" water, observe the water flow off the transom while the boat is underway.
- Allow headroom space above the bracket for it to release and rotate the sensor upward.
- Mount the sensor as close to the centerline (keel) of the boat as possible to ensure the transducer's face remains in the water when the boat is turning.
- **Single drive boat**—Mount at least 75 mm (3") beyond the swing radius of the propeller (see Figure 1). The starboard side where the propeller blades are moving downward is preferred.
- **Twin drive boat**—Mount the sensor between the drives.

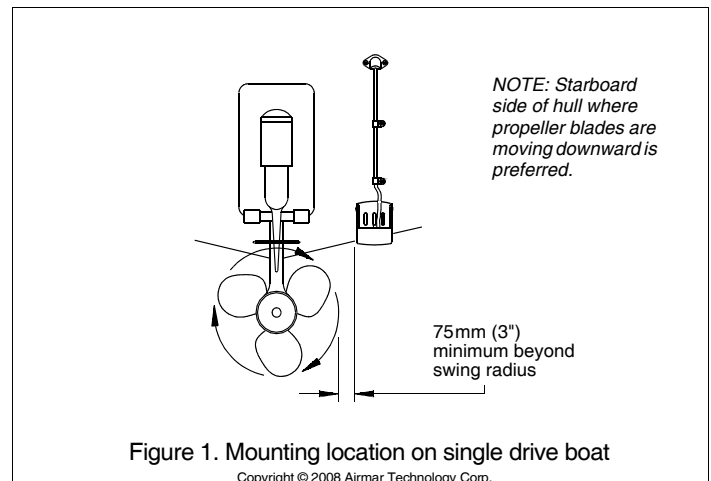

Figure 1. Mounting location on single drive boat

Copyright © 2008 Airmar Technology Corp.

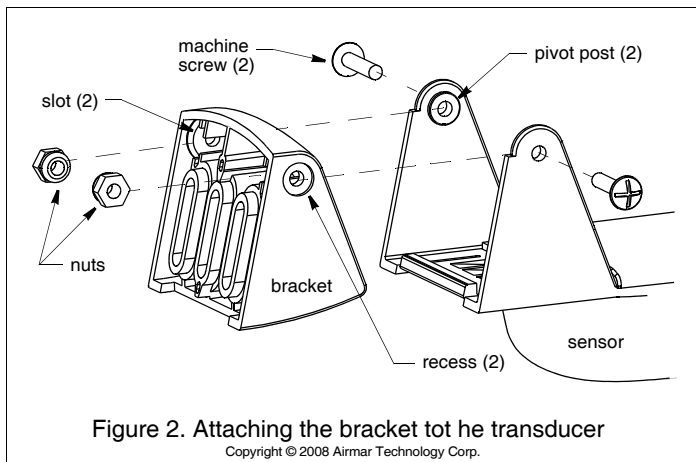

Figure 2. Attaching the bracket to the transducer

Copyright © 2008 Airmar Technology Corp.

Attaching the Bracket to the Transducer

1. Insert the sensor's pivot posts into the recesses on the sides of the bracket (see Figure 2).
2. Press the two nuts into the slots in the back of the bracket.
3. Align the holes in the sensor, bracket, and nuts. Insert the two machine screws capturing the nuts. Tighten the machine screws until the sensor will stay in the "up" (released) position unaided.

Hole Drilling

CAUTION: To prevent drilling too deeply, wrap masking tape around the bit 22mm (7/8") from the point.

Fiberglass hull—Minimize surface cracking by running the drill in reverse until the gelcoat is penetrated.

1. At the selected location, position the sensor, so it projects 3mm (1/8") below the bottom edge of the transom (see Figure 3).
2. *Being sure the bottom of the sensor is parallel to the waterline*, mark the location of the screw holes with an "X" in the center of the two outer most slots.
3. Using a 4mm, #23, or 9/64" drill bit, drill two holes 22mm (7/8") deep at the locations indicated.

Compensating for Transom Angle—Shims

For the best performance, the transducer beam must be aimed straight at the bottom. Since the transom of most boats is angled, the bracket must compensate for it. Measure the transom angle of the boat with an angle finder.

- **Standard transom (13° transom angle)**—The bracket is designed for a standard 13° transom angle. The 9° shim is *not* needed for this installation. If your boat is capable of speeds above 20kn (28MPH), install the bracket with the 4.5° shim, taper *down* (see Figure 4).
- **Stepped transom and jet boats (3° transom angle)** —Use the 9° shim with the taper *down* (see Figure 4). If your boat is capable of speeds above 20kn (28MPH), install the bracket with both the 9° and 4.5° shims, taper *down*. Install the 4.5° shim against the transom after shaving the interfering portion of the rails and lower bump. Place the 9° shim and bracket assembly on top.
- **Small aluminum and fiberglass boats (20° transom angle)**—Use the 9° shim with the taper *up* (see Figure 4). If your boat is capable of speeds above 20kn (28MPH), install the bracket with only the 4.5° shim, taper *up*.
- **If you are unsure about using the shim(s)**—Experiment with the shims by following the instructions "Mounting & Adjusting."

Mounting & Adjusting

CAUTION: Do not position the leading edge of the sensor lower than the trailing edge because aeration will occur.

CAUTION: Do not position the sensor deeper into the water than necessary to avoid increasing drag, spray, and water noise and reducing boat speed.

1. Apply marine sealant to the threads of two, #10 x 1-1/4", self-tapping bracket screws to prevent water seepage into the transom. *Be sure the nuts are in the slots in the back of the bracket and any shim(s) is in place* (see Figure 2). Screw the sensor to the hull (see Figure 3). *Do not tighten the screws completely at this time.*
2. Using a straight edge, sight the underside of the sensor relative to the underside of the hull (see Figure 4). The trailing edge of the sensor should be 1 – 6mm (1/16 – 1/4") below the leading edge.
3. Using the vertical adjustment space in the bracket slots, slide the sensor up or down until the bottom left corner of the sensor projections 0 – 3mm (0 – 1/8") below the bottom of the hull (see Figure 3). When you are satisfied with the position of the sensor, tighten the two bracket screws.

Testing on the Water

1. With the beam angle factory-set to 90°, become familiar with your echosounder's performance at a speed of 4kn (5MPH).
2. Gradually increase the boat speed and observe the gradual decline in performance due to turbulent water flowing over the sensor's active surface.
3. If the decline in performance is sudden (not gradual), identify the boat speed at which the onset occurred. Return the boat to this speed, then gradually increase speed while making moderate turns in both directions.
4. If the performance improves while turning to the side on which the sensor is installed, its position probably needs adjustment. The sensor is probably in aerated water.

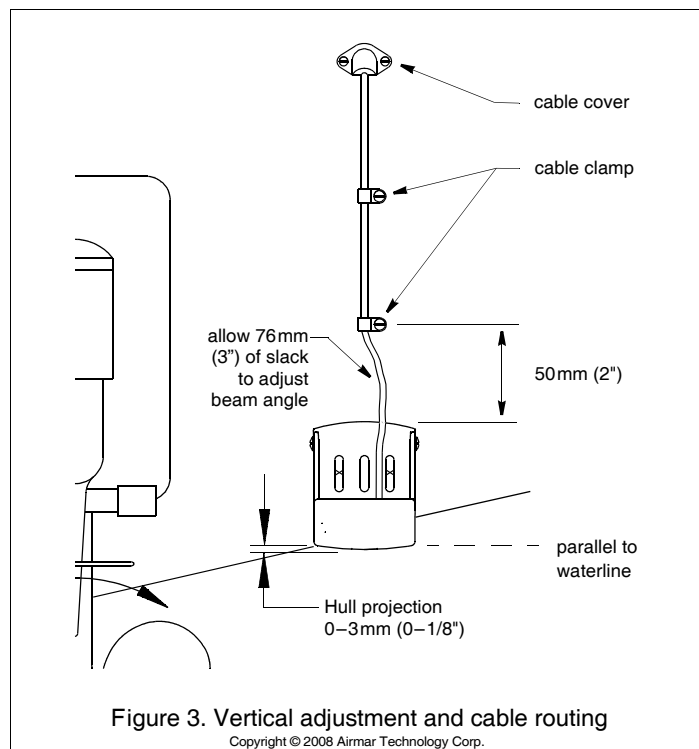
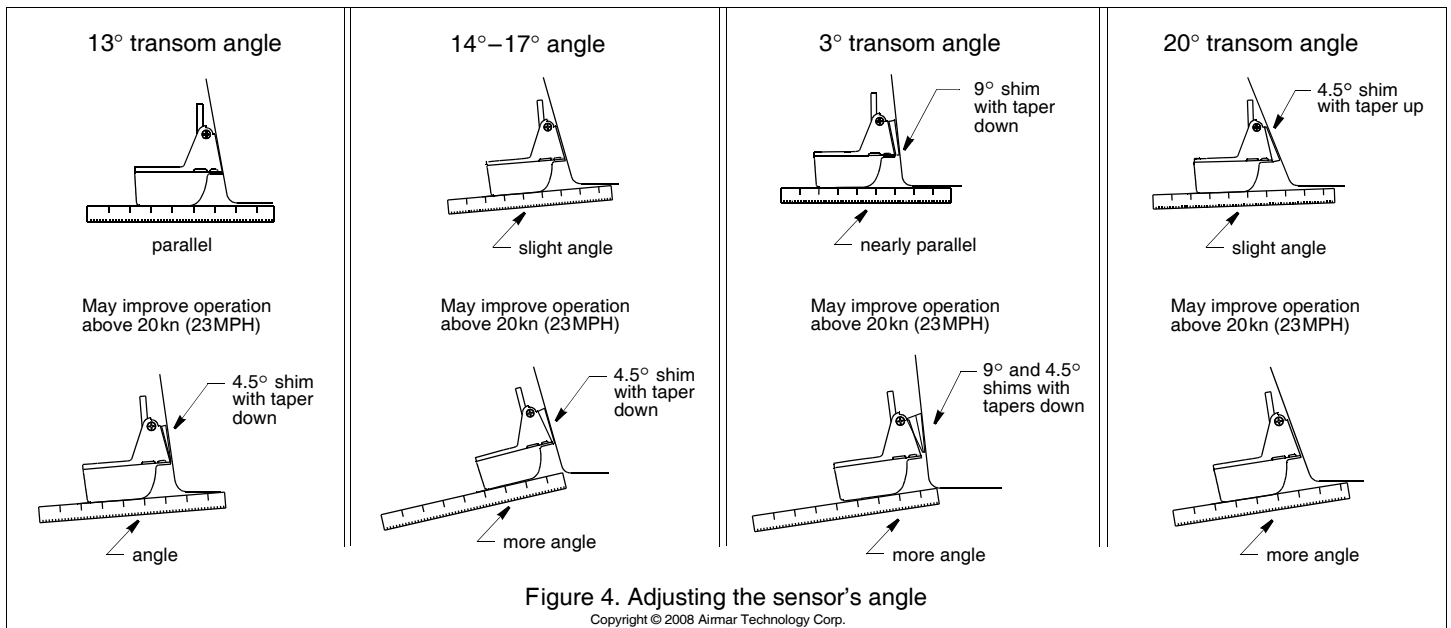

Figure 3. Vertical adjustment and cable routing

Copyright © 2008 Airmar Technology Corp.



To improve performance, try the following *one at a time* in the order given.

- a. Increase the sensor's transom angle in the water. Review "Compensating for Transom Angle—Shims" and see Figure 4.
- b. Move the sensor farther into the water in increments of 3mm (1/8") (see Figure 3).
- c. Move the sensor closer to the centerline of the boat. Fill unused screw holes with marine sealant.

Stabilizing the Bracket

Stabilize the bracket by installing the third bracket screw at the bottom of the center slot (see Figure 5). Using a 4mm, #23, or 9/64" drill bit, drill a hole 22mm (7/8") deep.

Apply marine sealant to the threads of the third #10 x 1-1/4" self-tapping screw to prevent water seepage into the transom. Tighten the screw.

Releasing the Bracket

CAUTION: Never strike the sensor with anything except the palm of the hand.

The sensor releases easily when it is fastened to the hull. Give a sharp blow to the bottom of the sensor using the palm of the hand.

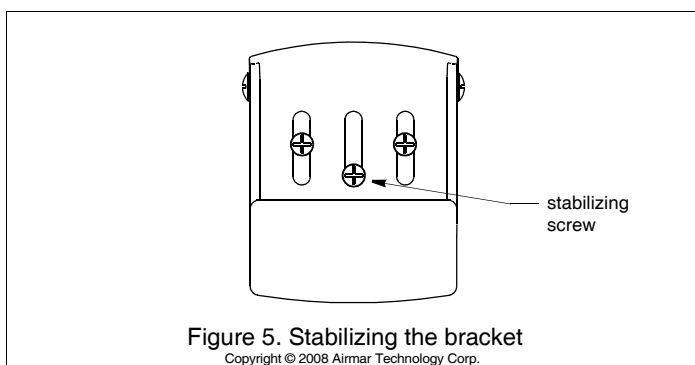

Cable Routing & Connecting

CAUTION: Do not remove the connector to ease cable routing. If the cable must be cut and spliced, use Airmar's splash-proof Junction Box No. 33-035 and follow the instructions provided. Removing the waterproof connector or cutting the cable, except when using a water-tight junction box, will void the sensor warranty.

Route the sensor cable over the transom, through a drain hole, or through a new hole drilled in the transom above the waterline.

1. If a hole must be drilled through the transom, choose a location **well above the waterline** (see Figure 3). Check for obstructions such as trim tabs, pumps, or wiring inside the hull. Mark the location with a pencil. Drill a hole using the appropriate size bit to accommodate the connector.
2. Route the cable over or through the transom.
3. On the outside of the hull, secure the cable against the transom using the cable clamps. Position one cable clamp 50mm (2") above the bracket and mark the mounting hole with a pencil.
4. Position the second cable clamp halfway between the first clamp and the cable hole. Mark this mounting hole.
5. If a hole has been drilled through the transom, open the appropriate slot in the cable cover. Position the cover over the cable where it enters the hull. Mark the two mounting holes.
6. At each of the marked locations, use a 3mm or 1/8" bit to drill a hole 10mm (3/8") deep.
7. Apply marine sealant to the threads of the #6 x 1/2" self-tapping screws to prevent water from seeping into the transom. If you have drilled a hole through the transom, apply marine sealant to the space around the cable where it passes through the transom.
8. Allowing an extra 76mm (3") of cable ease near the sensor, position the two cable clamps over the cable and fasten them in place. If used, push the cable cover over the cable and screw it in place.
9. Route the cable to the instrument being careful not to tear the cable jacket when passing it through the bulkhead(s) and other parts of the boat. Use grommets where appropriate. To reduce electrical interference, separate the sensor cable from other electrical wiring and the engine(s). Coil any excess cable and secure it in place with cable ties to prevent damage.
10. Refer to your echosounder owner's manual to connect the sensor to the instrument.

Checking for Leaks

WARNING: When the boat is placed in the water, **immediately** check for leaks around the screws and any other holes drilled in the hull. Note that very small leaks may not be readily observed. Do not leave the boat in the water unchecked for more than three hours.

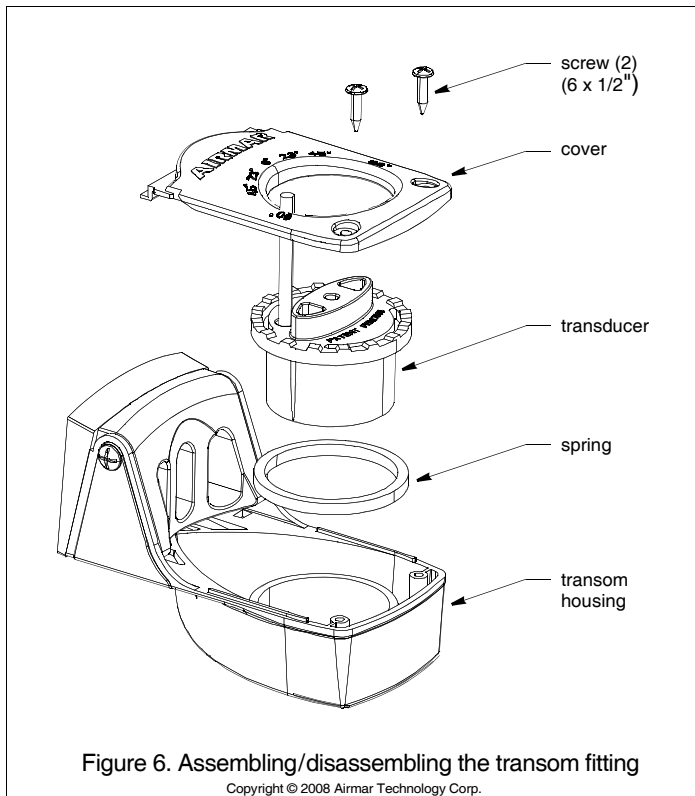

Trolling Motor Mount

Assembling the Fitting

1. Remove the transducer from the transom fitting by first removing the two screws and the cover (see Figure 6). Lift out the transducer and the spring.
2. Insert the spring and transducer in the trolling fitting (see Figure 7). Be sure the boss on the fitting engages the groove in the transducer.
3. Slide the locking ring along the cable until it rests against the transducer.
4. Using the two 6 x 3/4" screws supplied, screw the locking ring onto the trolling fitting. Be sure the notches in the locking ring mesh with the notches on the top of the transducer.
Hand-tighten only. Do not over-tighten.

NOTE: Do not use the screws from the transom fitting.

Locating & Installing the Fitting

CAUTION: Do not put tension to the cable where it exits the transducer, since excessive force can break internal connections.

CAUTION: On bow mounted motors, be sure the cable route does not result in pinching the cable when the motor is in the "up" position.

NOTE: It may be easier to adjust the beam angle before the transducer is mounted on the trolling motor. See "Operating" on page 5.

1. Purchase a stainless steel band clamp, available in the plumbing section of most hardware stores. Be sure to measure the circumference of the trolling motor to determine the correct size.
2. Loosen the screw in the band clamp so that one end of the band is free. Pass the free end through the two slots in the trolling fitting (see Figure 7).
3. Wrap the band clamp around the motor case with the sensor located on the underside (see Figure 8). Note that if the motor has a strut that shades the transducer, it will not significantly reduce the transducer's performance. *Being sure there is no tension on the cable where it exits the transducer*, tighten the screw on the band clamp.
4. Route the cable around the side of the motor case and along the support tube. Allow sufficient cable so the user can change the beam angle of the transducer. Secure the cable to the support tube with cable ties.
5. Route the cable to the echosounder being careful not to tear the cable jacket. To reduce electrical interference, separate the transducer cable from other electrical wiring.

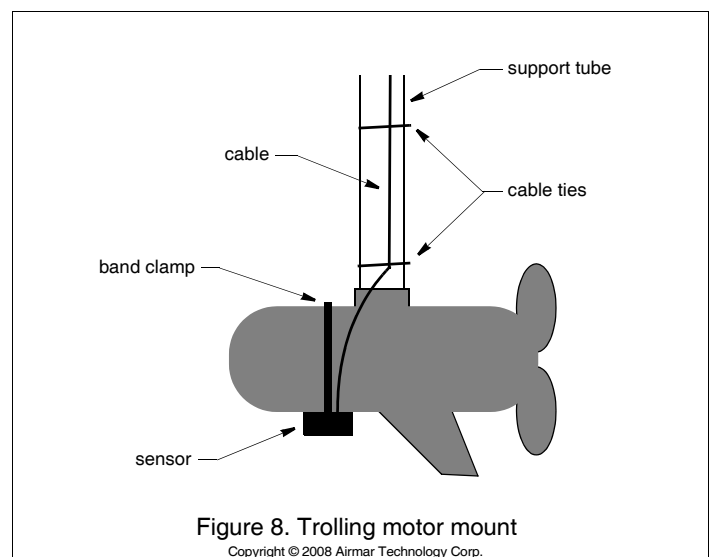
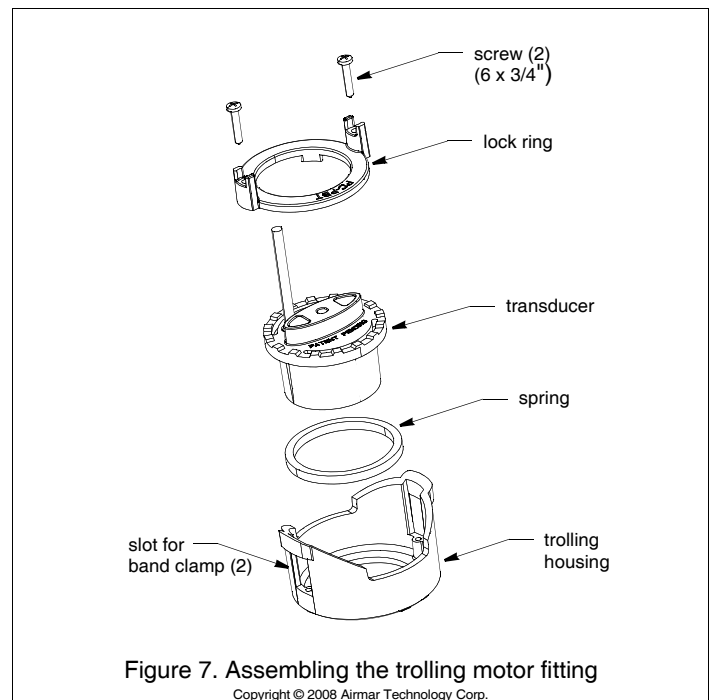

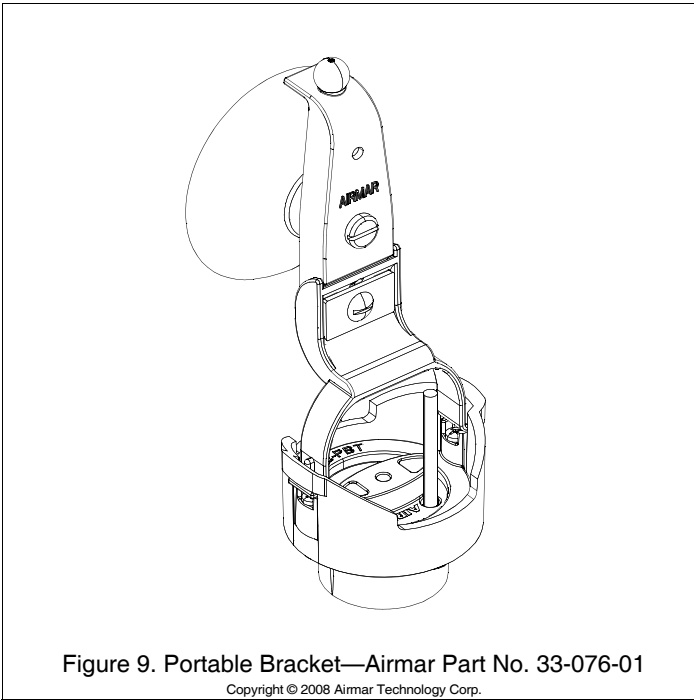

Portable Mount

An optional Portable Bracket Kit is available to temporarily mount the transducer to different watercraft, ice fishing apparatus, or a fixed location (see Figure 9). Installation instructions are included with the bracket.

In-Hull Mount

Although the performance will be diminished, the transducer can be adhered directly to a *solid* fiberglass hull—no coring. Instructions are available on the web at airmar.com. See Marine Products, Installation Instructions and click on “P72, P74, P76” (part number 17-010).

Operating

Adjusting the Beam Angle

The transducer transmits an elliptically shaped beam that can be adjusted to different angles: fore-aft (0°), port-starboard (90°), 23°, or 45°. The degree setting indicates the widest part of the beam. Note that the width of the beam will be different at each setting.

To understand when to use each beam setting see Table 1.

Table 1:

Setting	Fore-aft Beam Width	Port-starboard Beam Width	Application
0°	38°	12°	Best high-speed bottom detection Fish appear as large arches
23°	36°	18°	Good high-speed detection Fish appear as prominent arches Wider side-to-side beam than at 0°
45°	29°	29°	Detection similar to conventional wide-beam transducer Equal size beam width in both directions
90°	12°	38°	Maximum detection while boat is moving forward Good high-speed bottom detection Fish arches are not pronounced or may not be evident

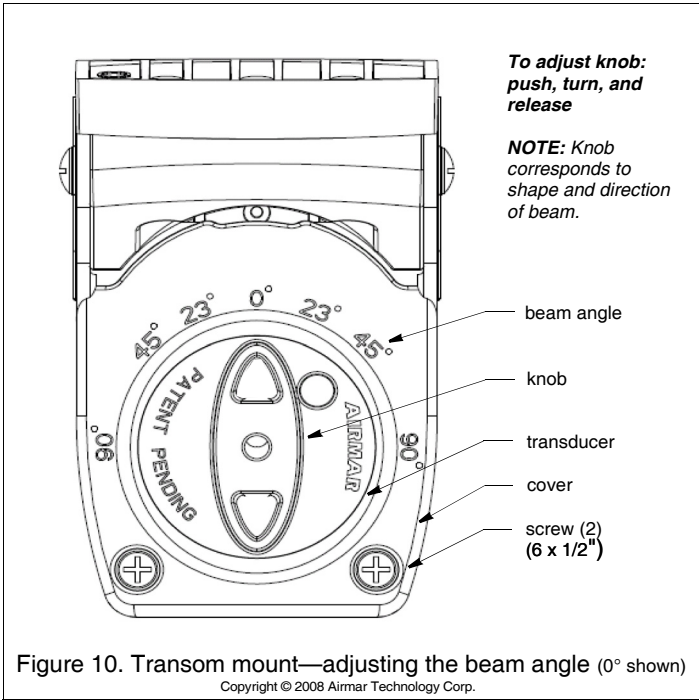

Transom Mount—To change the beam angle, grasp the transducer knob, push down, rotate to the desired setting, and release the knob (see Figure 10). *Check that the transducer is locked into the setting by running your hand along the bottom of the transducer to be sure it is flush with the fitting.*

NOTE: The knob corresponds to the direction and shape of the beam.

Trolling Motor & Portable Mounts—The beam angles are marked on the underside of the trolling motor fitting (see Figure 11). To change the beam angle, grasp the transducer and pull outward. Rotate it until the orientation mark is aligned with the desired setting and release the transducer. *Be sure the transducer is locked into the setting after the knob is released.*

NOTE: When an angle is set, the orientation mark will indicate the direction of the widest part of the beam. It will also be aligned with the elliptically shaped knob on the top.

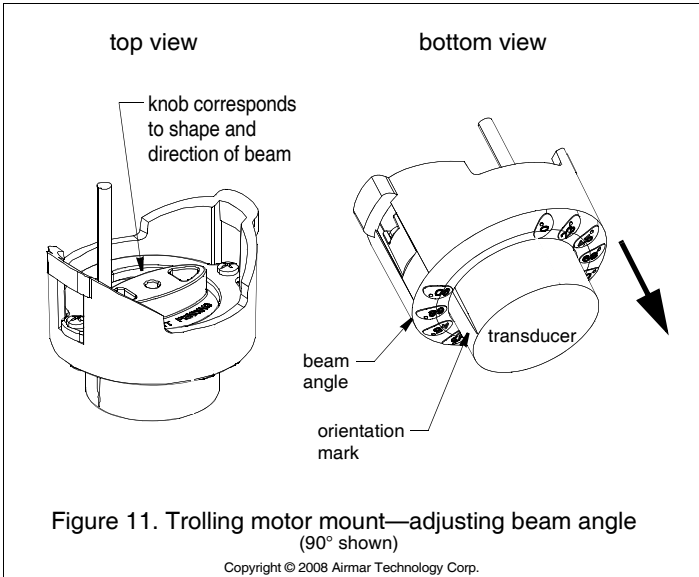

Anti-fouling Paint

Aquatic growth can accumulate rapidly on the sensor's surface reducing performance within weeks. Surfaces exposed to salt water *that do not interlock*, must be coated with anti-fouling paint. Use **water-based** anti-fouling paint only. Never use ketone-based paint, since ketones can attack many types of plastic possibly causing damage to the sensor. Apply paint every 6 months or at the beginning of each boating season.

Maintenance

Cleaning

Clean the transducer's surface with a Scotch-Brite® scour pad and mild household detergent taking care to avoid making scratches. If the fouling is severe, lightly wet sand with fine grade wet/dry paper.

Damaged Cable Jacket

1. Should the outer jacket of the cable be abraded or cut, check that the internal conductors are not damaged.
2. If the conductors are damage free, allow the cable to dry and fill the damaged area with sealant.
3. Cover the damaged area with electrical tape.

Severed Cable

1. Slide heat-shrink tubing onto the cable.
2. Splice each pair of matching colored conductors with rosin core solder.
3. Wrap each conductor with insulating tape at the splice.
4. Splice the braided shield wire with solder.
5. Fill the spliced area in the cable with sealant.
6. Cover the damaged area with the heat shrink tubing, following the manufacturer's directions for its use.

NOTE: *If the instrument fails to provide a reading, the problem may not be the damaged cable. The transducer, connector, or instrument could be defective.*

Reassembling the Transom Fitting

1. Slide the cover over the cable onto the transducer (see Figure 6).
2. While holding the wavy spring over the pocket in the transom fitting, insert the transducer into the pocket. (The spring fits under the lip of the transducer.) Orient the transducer so the knob is facing 90° and the cable exits near the bracket at about the 45° mark.
3. Using the two 6 x 1/2" screws supplied, fasten the cover onto the transom fitting. **Hand-tighten only.** *Do not over-tighten.*
NOTE: *Do not use the screws from the trolling motor fitting.*

Parts & Accessories

The information needed to order a replacement transducer is printed on the cable tag. Do not remove this tag. When ordering, specify the part number, date, and frequency in kHz. For convenient reference, record this information on the top of page one.

Lost, broken, or worn parts should be replaced immediately.

Bracket & Wedge Kit	33-491-01
Portable Bracket Kit	33-076-01 (see Figure 9)

Obtain parts from your instrument manufacturer or marine dealer.

Gemeco (USA)	Tel: 803-693-0777 Fax: 803-693-0477 email: sales@gemeco.com
Airmar EMEA (Europe, Middle East, Africa)	Tel: +33.(0)2.23.52.06.48 Fax: +33.(0)2.23.52.06.49 email: sales@airmar-emea.com