

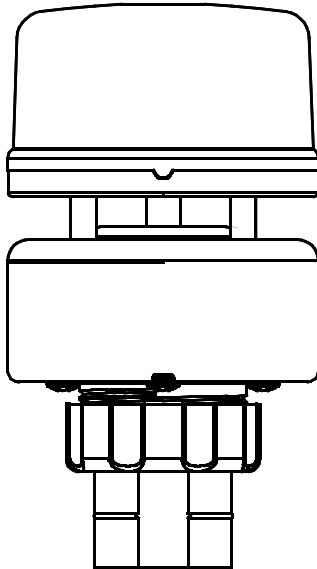

Owner's Guide & Installation Instructions

WeatherStation® Instrument

Models: **300WXR**
300WX
150WX
110WX
100WX
PB200
PB150
LB150



Patents Pending

Record the serial number found on the underside of the instrument.

Serial No. _____ Date of Purchase _____

17-461-01 rev.06

10/03/11

Copyright © 2008 - 2011 Airmar Technology Corp. All rights reserved.

All Rights Reserved. Except as expressly provided herein, no part of this manual may be reproduced, copied, transmitted, disseminated, downloaded, or stored in any storage medium, for any purpose without prior written consent of Airmar. Airmar hereby grants permission to download a single copy of this manual and of any revision of this manual onto a hard drive or other electronic storage medium to be viewed and to print one copy of this manual or any revision hereto, provided that such electronic or printed copy of this manual or revision must contain the complete text of this copyright notice and provided further that any unauthorized commercial distribution of this manual or any revision hereto is strictly prohibited.

Information in this manual is subject to change without notice. Airmar reserves the right to change or improve its products and to make changes in the content without obligation to notify any person or organization of such changes. Visit the Airmar website at www.airmar.com for current updates and supplemental information concerning the use and operation of this and other Airmar products.

Table of Contents

Introduction & Features.....	4
Outputs & Functions.....	5
Safety Instructions.....	6
Importance of True Wind.....	7
Adding External Sensors.....	7
Hardware.....	8
Tools & Materials.....	9
Where to Purchase Parts.....	9
Choosing the Mounting Location.....	10
Installing.....	11
Cable Routing & Connecting Guidelines.....	14
Connecting to an NMEA 0183 Display.....	15
Connecting to an NMEA 2000® Network.....	17
Calibrating the Compass.....	18
Maintenance.....	19
Installing the Humidity Sensor.....	20
Software.....	20
Troubleshooting.....	21
Technical Information.....	22
Acronyms & Glossary.....	23

IMPORTANT: Please read the Owner's Guide completely before proceeding.

Introduction

Thank you for purchasing Airmar's ultrasonic, WeatherStation Instrument. This exciting product has multiple sensors in a single unit—without any moving parts. The compact housing is waterproof with a single removable cable. Functions and features vary by model.

Features

- Waterproof housing and cable system
- Fast response time and update rate
- Stable and accurate true wind and heading data in dynamic conditions
- Can be programmed to compensate for an installation that is not aligned to the front of the boat/vehicle and/or level
- Can be calibrated to compensate for magnetic deviation caused by ferrous metals and other electro-magnetic fields
- GPS with WAAS and EGNOS

Table 1: Outputs & Functions

	300WXR	300WX	150WX	110WX	100WX	PB200	PB150	LB150
Apparent wind speed and angle	*	*	*	*	*	*	*	*
True wind speed and direction	*	*	*			*	*	*
True wind speed relative to water	*	*	*			*	*	
Heater to keep wind channel free of ice	A	A	A	A				
Air temperature	*	*	*	*	*	*	*	*
Apparent wind chill temperature	*	*	*	*	*	*	*	*
True wind chill temperature	*	*	*			*	*	*
Barometric pressure	*	*	*	*	*	*	*	*
Relative humidity	B	B	B	B				*
Dew point temperature	B	B	B	B				*
Heat index temperature	B	B	B	B				*
Rain intensity	*							
Rain accumulation	*							
Rain event duration	*							
Peak time of rain intensity	*							
Magnetic compass heading	C	C	D			C	D	D
Heading relative to true north	*	*	*			*	*	*
Rate of Turn	*	*				*		
Angle of pitch and roll	*	*	*			*	*	*
Rate of pitch & roll	*	*						
Global Positioning System (GPS)	*	*	*			*	*	*
NMEA 0183; RS232	*	*	*	*	*			
NMEA 0183; RS422	*	*	*	*	*	*	*	*
NMEA 2000®; CAN	*	*	*	*		*		

- A. Optional heater
- B. Optional humidity sensor
- C. 3-axis compass
- D. 2-axis compass

WARNING

Navigation Aid Only—The WeatherStation Instrument is only an aid to navigation and should never be solely relied upon. It is not a replacement for traditional navigation aids and techniques. Only official government charts contain all the information needed for safe navigation.

Follow the safety precautions below to reduce the risk of poor product performance, property damage, personal injury, and/or death.

WARNING: Correct Installation Important

The WeatherStation Instrument must be installed and operated according to the instructions in this owners guide.

WARNING: Installation Safety

Always wear safety goggles and a dust mask when installing.

WARNING: Compass Safe Distance

The WeatherStation Instrument must be a minimum of 0.3m (1') from other standard and steering compasses.

WARNING: Do Not Install Near Artificial Magnetic Field

The WeatherStation Instrument must be a safe distance from ferrous metals and anything that can create a magnetic field to prevent interference to the magnetic compass.

WARNING: Electrical Safety

The power supply must be OFF before making electrical connections.

WARNING: Voltage

The power supply voltage must be that specified for the model.

- WX models 9 - 40 VDC
- LB and PB models 9 - 16 VDC
- Models with heater 24VDC only

WARNING: Fuse or Circuit Breaker

A safe installation requires a 0.5 amp fast-blow fuse or circuit breaker. Except, models with a heater require a 3 amp fast-blow fuse or circuit breaker.

WARNING: Battery

Make power connections to a power source that is isolated from the engine start battery(s). Voltage drops may cause the instrument to lose information and/or change operating mode.

WARNING: Calibrating the Compass

The internal compass may need to be calibrated after the WeatherStation Instrument is installed. Perform the pretest to determine if calibration is necessary.

WARNING: 150WX, LB150, PB150

These models incorporate a two-axis compass. Significant errors can occur in the heading when a vehicle/boat is pitching and rolling. If there is an error in the heading, there also will be a corresponding error in the true wind direction. Errors can be minimized or eliminated by using data from an external compass.

The Importance of Understanding True Wind Direction

When the WeatherStation Instrument is stationary, the direction *from which* the wind is blowing is known as the *true wind*. The WeatherStation Instrument is programmed to measure the direction based upon the specific orientation of the sensor. For the WeatherStation Instrument to accurately calculate the true direction of the wind, *it must be installed and oriented correctly*.

To learn more about true and apparent wind direction, visit www.airmar.com and go to Installation Instructions and Owner's Guides > WeatherStation Instruments or see the "How the WeatherStation Instrument Works" on the WeatherCaster CD.

Adding External Sensors

Some WeatherStation Instruments can receive data from an external sensor(s). The WeatherStation Instrument will automatically detect whether a sensor(s) is internal, external, or not available at all. The WeatherStation Instrument gives priority to valid external-sensor data when available.

- **NMEA 0183**—Simply connect the sensor(s) to a Combiner or other NMEA 0183 repeater hardware.
- **NMEA 2000®**—Connect the sensor(s) to the NMEA 2000 network.

NOTE: *When an external speed sensor is connected to both an NMEA 0183 device and an NMEA 2000 network, the WeatherStation Instrument will use NMEA 2000 data.*

- **PB150, LB150**—If an external electronic compass is installed and working, this external compass data will override the WeatherStation Instrument compass.
- **Speed-through-water sensor**—An external speed sensor can be installed, such as an Airmar Smart™ Sensor. Airmar recommends installing the DST800V to receive water depth, boat speed, and water temperature data.

Cables & Connecting/Converting Hardware

The WeatherStation Instrument can be connected to a device and/or network in several ways. **You must have the correct cable and any needed converting/connecting hardware before beginning the installation.**

WeatherStation Cables

	<u>Length</u>	<u>Part No.</u>
• NMEA 0183 Cable	10m	33-862-02
• NMEA 0183 Cable (for instrument with heater)	10m	33-1167-01
• NMEA 2000® Cable	6m	33-1029-02
• NMEA 2000® Cable	10m	33-1104-01

NOTE: Additional cable lengths are available.

Connecting/Converting Hardware

• NMEA 0183 to USB Converter		33-801-01
• NMEA 0183 Combiner		33-800-01
• NMEA 2000® CAN to USB Gateway		33-727-01
• NMEA 0183 & NMEA 2000® Splitter	15m	33-632-01
• NMEA 0183 & NMEA 2000® Splitter	30m	33-632-02

Mounts

CAUTION: Vehicles/boats traveling above 30MPH—Do not use the plastic Cable Side-exit Adaptor (part D) supplied. Purchase a stainless steel part. At high speeds, the plastic adaptor may break, causing the instrument to fall off.

NOTE: The WeatherStation nut has standard 1"-14 UNS or 3/4" NPT threads.

Antenna mount with standard marine 1" -14 threads and pass-through for cable (see Figure 1)

Hardware to install antenna mount
Extension tube (some installations)

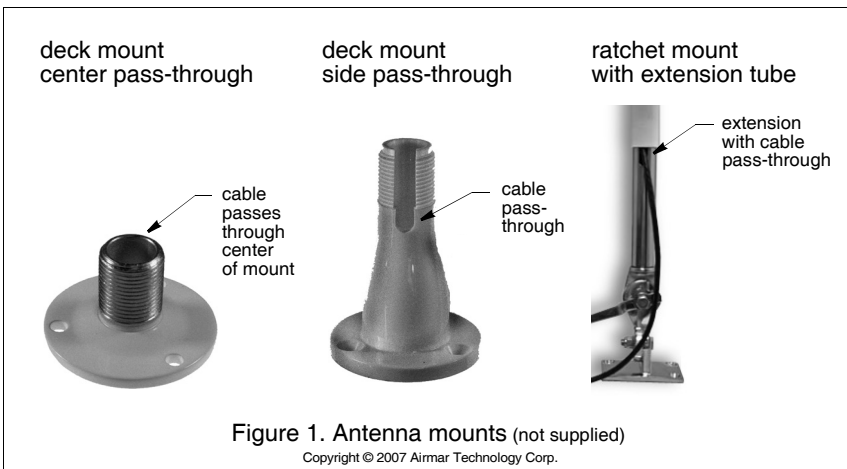

Choosing the Mounting Location

For accurate readings and a reliable GPS signal, selecting the best location for the WeatherStation Instrument is very important. Easy access and appearance should be secondary considerations. Since each installation is unique, the best separation distances from other equipment will vary depending on the particular equipment and how it is configured. Choose a location that balances the requirements below.

- The WeatherStation Instrument must be mounted in “clear air”—away from obstructions in any direction that will interfere with air flowing through the unit. If there is an obstruction, be sure to mount the WeatherStation Instrument at least 2m (6') away. On land, avoid roof tops, chimneys, trees, etc.
- If possible, mount the WeatherStation Instrument higher than any other object. Mount it a minimum of 500mm (20") above the surrounding surfaces. Note that the higher the WeatherStation Instrument is mounted, the less accurate the pitch and roll readings will be.
- To prevent interference to the internal magnetic compass:
 - Mount a minimum of 0.3m (1') from other standard and steering compasses.
 - Mount away from any structures or equipment that contains ferrous metals.
 - Mount away from anything that may create a magnetic field such as magnetized materials, electric motors, electronic equipment, engines, generators, power/ignition cables, and batteries. For distances, follow the respective manufacturer's recommendations.
- To prevent interference to the internal GPS:
 - It must have a clear view of the sky to receive satellite signals. Check for any obstructions such as other boats or buildings.
 - Mount it lower than any on-board INMARSAT communications antenna.
 - Mount it as far as possible from high-powered transmitting antennas to avoid mutual interference (see Figure 2).

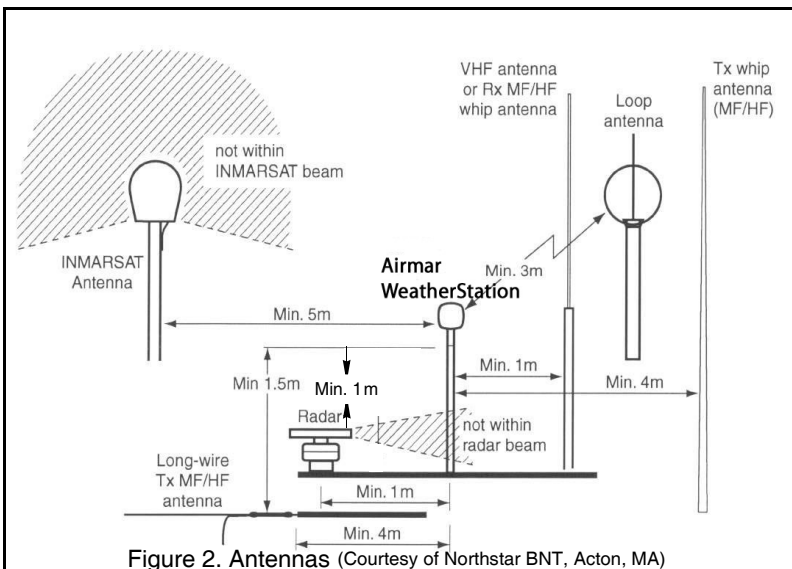

Installing

CAUTION: The reflector plate and the waterproof film found in the wind channel of the WeatherStation Instrument are essential to its operation (see Figure 3). Be careful not to scratch the plate, puncture the film, or damage them in any way.

CAUTION: The WeatherStation Instrument must be installed upright and vertically—NOT tilted to one side. If the WeatherStation Instrument is tilted from the horizontal plane, it may introduce an error in the compass and wind readings.

CAUTION: To accurately measure the wind direction and vehicle/boat heading, the alignment indentation on the WeatherStation Instrument must be pointed correctly.

- Moving vehicle/boat—The alignment indentation must point forward and be parallel to the centerline of the vehicle/boat.
- Stationary surface—It is recommended that the alignment indentation point toward true north.

CAUTION: Do not tighten or align the WeatherStation Instrument by rotating the upper cap. Turning may sever internal connections and void the warranty. Grasp the lower housing below the reflector plate. Hand tighten only.

CAUTION: If you use a thread lock, use teflon pipe-thread tape. Do not use a liquid thread lock as it may weaken the plastic, causing it to swell and crack.

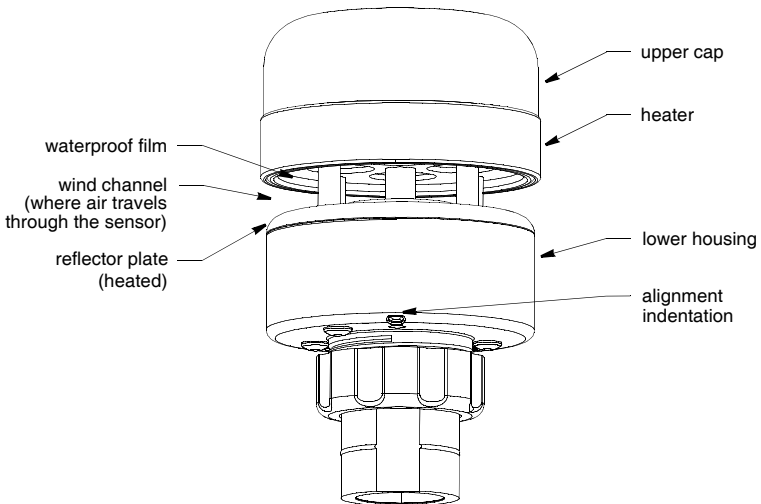

Figure 3. WeatherStation Instrument (150WX with heater shown)

Copyright © 2008 - 2011 Airmar Technology Corp.

Permanent Mounting

1. Place the mounting hardware at the selected location. Orient any cable exit in the direction that you want the cable to travel.
2. Position the mounting hardware at a 90° angle to the mounting surface. If necessary, use shims to make the mounting surface level (see Figure 4).
3. Mark the holes for the screws (see Figure 1). If the cable will pass through the center of the mount, also mark that hole.

NOTE: If you are using a ratchet mount, be sure you have purchased an extension with a cable pass-through.

4. Drill the holes for the mounting screws and the cable exit if necessary. If the cable is to be fed through a deck, install a high quality deck gland.
5. Using purchased screws, fasten the mount in place.
6. Screw an extension tube onto the antenna mount if desired (see Figure 4).

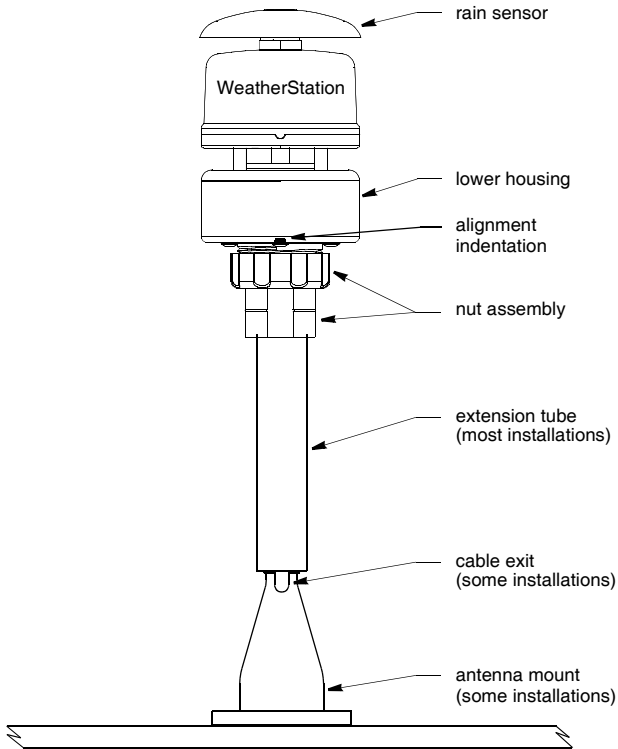

Figure 4. Installation (300WXR shown)

Copyright © 2007 - 2011 Airmar Technology Corp.

Attaching the Cable to the WeatherStation Instrument

1. With the nut assembly on the cable near the WeatherStation connector, thread the cable through the extension tube (if used), antenna mount, and the cable exit. *Be sure to leave several inches of cable extending beyond the nut assembly (see Figure 5).*
2. Screw the nut assembly onto the top of the antenna mount/extension tube. **Hand tighten** only. Do not over tighten.
NOTE: *If you use a thread lock, use teflon pipe thread tape only.*
3. Remove the protective cover from the connector. (Save the cap to protect the connector, when the WeatherStation Instrument is removed.) Plug the connector into the WeatherStation Instrument. The alignment key on the connector fits into a notch in the base of the WeatherStation Instrument.
4. To accurately measure the wind direction, be sure to orient the alignment indentation correctly. Grasp the lower housing of the WeatherStation Instrument below the reflector plate and hold it in the proper position (see Figure 4).
 - Moving vehicle/boat—The alignment indentation must point forward and be parallel to the centerline of the vehicle/boat.
 - Stationary surface—It is recommended that the alignment indentation point toward true north.
5. Slide the captive nut upward and screw it onto the base of the WeatherStation Instrument (see Figures 4 and 5). **Hand tighten** only. Do not over tighten. *Be careful not to rotate the WeatherStation Instrument changing the alignment or loosen the nut assembly from the antenna mount/extension tube.*

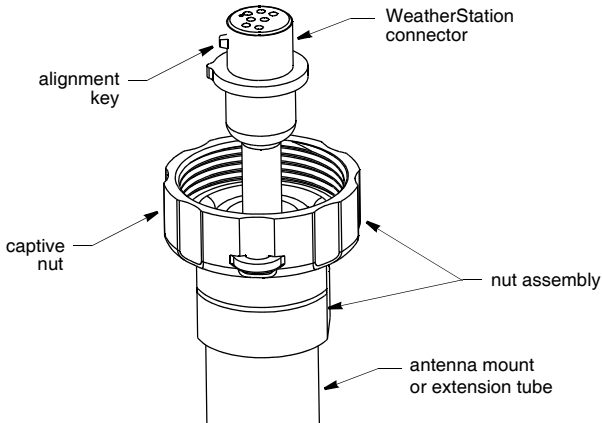

Figure 5. Attaching the cable to the WeatherStation Instrument

Copyright © 2007 - 2011 Airmar Technology Corp.

Cable Routing & Connecting

Depending on the equipment you will be using, route the WeatherStation cable to an Airmar Converter, Combiner, or Splitter; an NMEA 0183 display or an NMEA 2000 network. After reading the cautions below, go to the appropriate instructions.

WARNING: The power supply must be OFF before making electrical connections.

WARNING: The power supply voltage must be that specified for the model.

300WXR	9 - 40 VDC
300WX	9 - 40 VDC
150WX	9 - 40 VDC
110WX	9 - 40 VDC
100WX	9 - 40 VDC
PB200	9 - 16 VDC
PB150	9 - 16 VDC
LB150	9 - 16 VDC
Models with heater	24VDC <i>only</i>

WARNING: A safe installation requires a 0.5 amp fast-blow fuse or circuit breaker. Except, models with a heater require a 3 amp fast-blow fuse or circuit breaker.

WARNING: Make power connections to a power source that is isolated from the engine start battery(s). Voltage drops may cause the instrument to lose information and/or change operating mode.

CAUTION: Do not remove the waterproof connector(s) to ease cable routing. Buy a cable without a connector. Instructions for wiring are supplied.

CAUTION: To reduce electrical interference from other electrical wiring and any on-board equipment with strong magnetic fields such as: radar equipment, radio transmitters, engines, generators, etc., separate the cables by at least 1 m (3'). Ensure that all the cable shields are appropriately grounded.

CAUTION: Be careful not to tear the cable jackets when passing them through compartments, bulkheads, or walls. Use grommets to prevent chaffing.

CAUTION: Use a multimeter to check the polarity and the connections to the power supply before applying power to the WeatherStation Instrument.

CAUTION: Coil any excess cable(s) and secure it with cable ties to prevent damage.

Connecting to an Airmar Converter, Combiner, or Splitter

Follow the installation instructions that are supplied with the unit.

Connecting to an NMEA 0183 Display

Route the WeatherStation cable to the display. *Do not fasten the cable in place at this time.*

Connector on Display End

If your WeatherStation cable has a connector on the display end, and it can be plugged into the port on your NMEA 0183 display; do so now. Coil any excess cable and secure it with cable ties to prevent damage. Fasten the cable in place.

No Connector on Display End: Wiring

If your WeatherStation cable does not have a connector on the display end, it must be hard wired. Referring to the owner's manual that came with your display, connect the colored wires as shown in either Figure 6 or 7.

NOTE: *If your display does not have NMEA 0183 output connections, the yellow and orange wires are not needed. Apply heat-shrink tubing to each unused wire. (Alternatively, the yellow and orange wires can be connected to an external sensor.)*

NOTE: *The display power may be wired directly to the WeatherStation cable, or it may be wired separately. Models with a heater MUST be wired separately.*

1. Allowing an extra 25 cm (10") for wiring ease, cut the cable to length.
2. Strip 60mm (2-1/2") of the outer jacket and foil shielding from the cut end of the cable (see Figure 6 or 7).
3. Strip 10 mm (3/8") of conductor insulation from the end of each colored wire.
4. Protect the cable's foil shielding from causing a short by using heat-shrink tubing around the jacket where the wires emerge from the cable. The tubing must overlap the wires a minimum of 6mm (1/4"). Shrink the tubing using a heat gun.
5. Being sure the power supply is OFF, connect the wires to the display.
6. Fasten the cable in place.
7. Your installation is complete. To begin receiving data, refer to the owner's manual that came with your display.

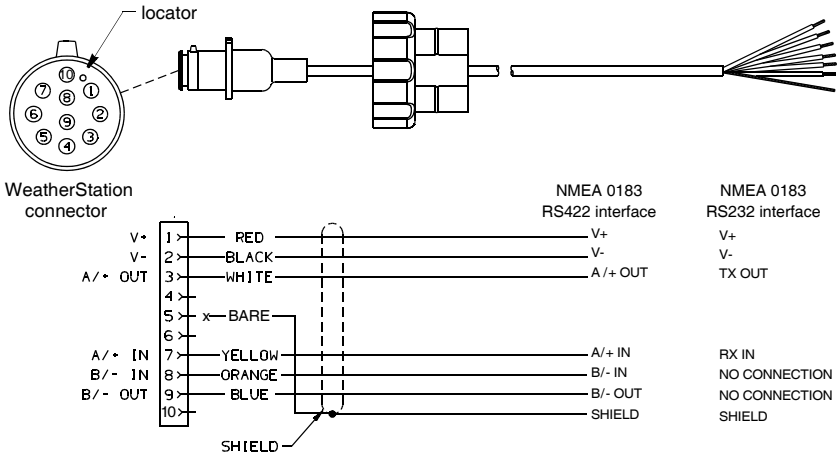

Figure 6. NMEA 0183 WeatherStation Cable—no heater

Copyright © 2007 - 2011 Airmar Technology Corp.

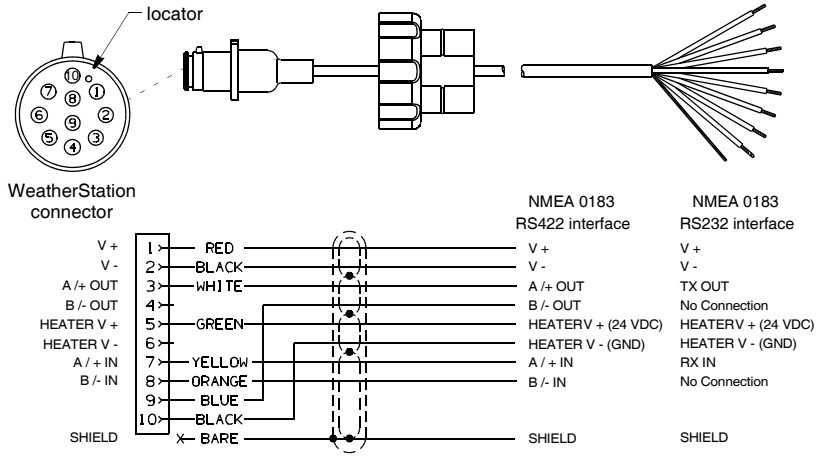

Figure 7. NMEA 0183 WeatherStation Cable—with heater

Copyright © 2011 Airmar Technology Corp.

Connecting to an NMEA 2000® Network

CAUTION: Only two termination resistors are required on an NMEA 2000 network. More than two will degrade the bus performance.

Route the WeatherStation cable to the NMEA 2000 network. Plug the NMEA 2000 connector into the network node (see Figure 8). Coil any excess cable and secure with cable ties to prevent damage.

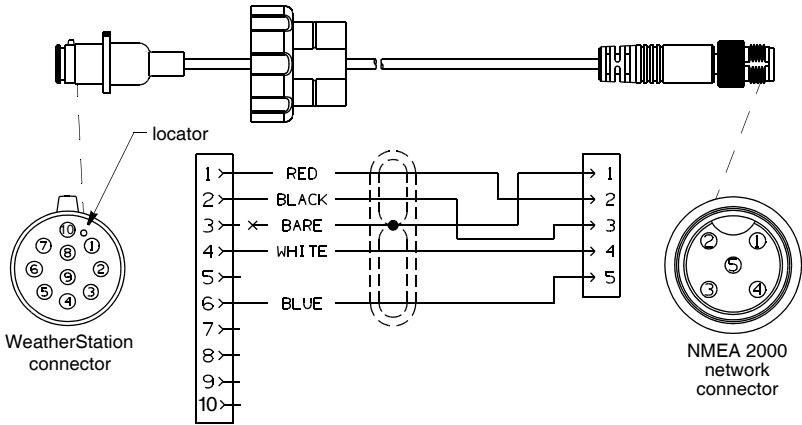

Figure 8. NMEA 2000® WeatherStation Cable [6m (20') shown]

Copyright © 2008 - 2011 Airmar Technology Corp.

NOTE: Weatherstation cables longer than 6m (20') have a termination resistor built into the sensor connector (see Figure 9).

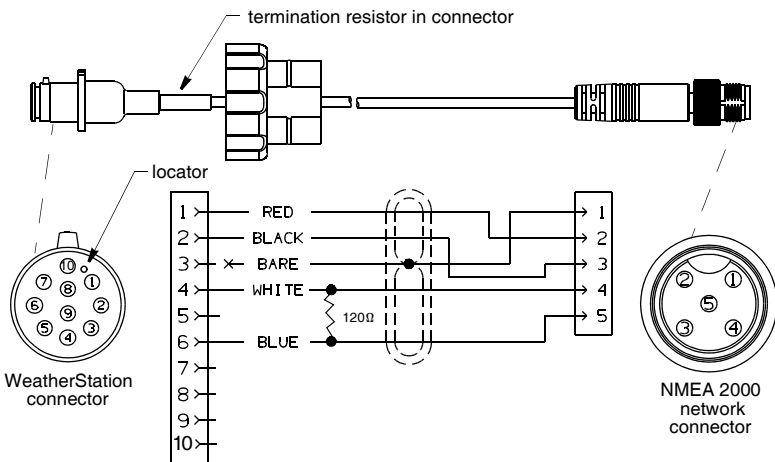

Figure 9. NMEA 2000® WeatherStation Cable [10m (33') shown]

Copyright © 2009 - 2011 Airmar Technology Corp.

Calibrating the Compass

WARNING: The internal compass may need to be calibrated after the instrument is installed for maximum accuracy. Perform the pretest below to determine if calibration is necessary.

CAUTION: Boat—The Pretest and AutoCalibration Procedure must be done in calm seas in a 0.8 km (0.5 mile) open area away from other boats and ferrous objects such as structures and aids to navigation. Avoid congested areas and waters with strong currents as calibration will be difficult and possibly hazardous.

Pretest

Go to an appropriate site.

- **Vehicle**—Drive to an open parking lot or field, away from other vehicles and ferrous objects.
- **Boat**—In calm seas, navigate to an open area of water, 0.8 km (0.5 mile) of open space away from other boats and ferrous objects.

While making a full circle, compare the WeatherStation heading data to another compass. Check all headings. If the data agrees, there is no magnetic influence on the WeatherStation Instrument. The compass does NOT need to be calibrated. *If the data does not agree, continue with the calibration instructions below.*

How to Calibrate

Calibration can be done in one of two ways.

- Calibrate the compass using the WeatherCaster™ software and a PC.
- Follow the AutoCalibration Procedure below.

AutoCalibration Procedure

IMPORTANT: Calibration requires the vehicle/boat to complete 2 to 3 circles.

IMPORTANT: In the event of a calibration failure, repeat the procedure.

1. At the site where the pretest was performed, select the display page on the NMEA Instrument that shows Heading.
2. Shut OFF and then turn ON the DC power that is connected to the WeatherStation Instrument.
3. Within 2 minutes of cycling power to the WeatherStation Instrument, start the vehicle/boat in a slow [4.5 to 7 MPH (4 to 6 knots)] circular turn that takes about 2 to 3 minutes to complete.*

If the vehicle/boat completes 1.5 circles within 3 to 4.5 minutes, AutoCalibration will begin. Heading will stop being reported on any NMEA 0183 or NMEA 2000 display until the calibration is finished.

4. Keep turning in the same circle for 1 to 2 more complete circles.
Do not change the speed or rate of turn through the circle.
5. When calibration is completed successfully, Heading will return to the display. If calibration fails, the display will flash Heading ON and OFF in 10 second intervals for 60 seconds. (Display times may vary by manufacturer.)

* The optimum rate of turn is 180°/minute: 3°/second, 30°/10 seconds, 45°/15 seconds, and 90°/30 seconds.

Maintenance

CAUTION: Do not disassemble the WeatherStation Instrument. There are no user-serviceable parts inside. Removing the three screws holding the lower housing will damage the waterproof seal, voiding the warranty.

CAUTION: Do not immerse in water or pressure wash. Doing so may allow water to infiltrate the WeatherStation Instrument, voiding the warranty.

CAUTION: The reflector plate and the waterproof film found in the wind channel of the WeatherStation Instrument are essential to its operation. The waterproof film protects the transducers, so be careful to keep it intact. Do not scratch the reflector plate or damage it in any way.

CAUTION: Avoid damaging the rain sensor. If the umbrella becomes chipped or cracked, readings from the sensor may be incorrect. If the umbrella does become damaged, return the WeatherStation Instrument to the factory to replace the umbrella and re-calibrate the rain sensor.

IMPORTANT: Keep the wind channel free of SPIDER WEBS, insects, dirt, and other debris. Keep the temperature and humidity sensors clean.

Cleaning

Since the WeatherStation Instrument has no moving parts, it requires minimal maintenance. Clean with a damp cloth and mild household detergent (see Figure 10). Gently thread an alcohol wipe through the wind channel to remove spider webs and any debris.

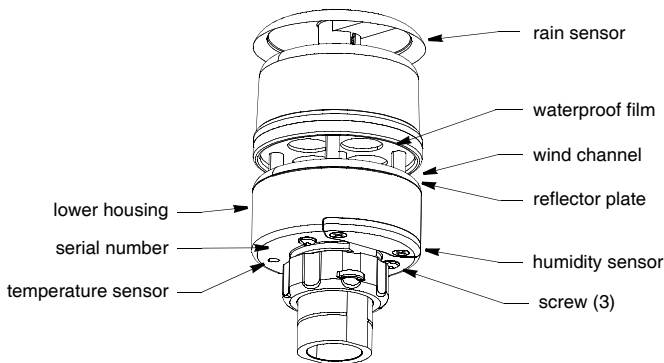

Figure 10. Maintenance (300WXR shown)

Copyright © 2008 - 2011 Airmar Technology Corp.

Humidity Sensor: 110WX, 150WX, 300WX, 300WXR

1. Remove the two screws from the humidity sensor or blank (see Figure 11).
2. Remove the sensor or blank.
3. Push the new humidity sensor into place. Fasten it with the two screws supplied. Using a torque wrench, apply 0.25 - 0.30Nm. **Do not over tighten.**

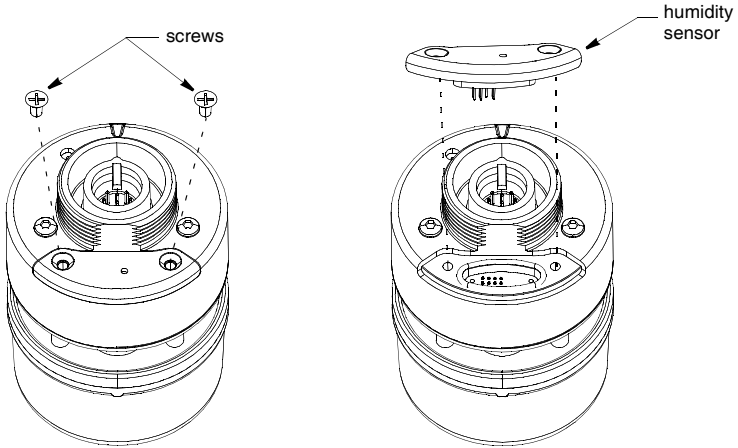

Figure 11. Replacing the humidity sensor

Copyright © 2011 Airmar Technology Corp.

Software

Software Updates

Airmar may release updated versions of both the WeatherStation firmware and the WeatherCaster™ software. Check Airmar's website at www.airmar.com to download the latest revision, or contact Airmar's technical support personnel for a CD.

Installing WeatherCaster™ Software

Follow the instructions in the *WeatherCaster Software Guide*.

Troubleshooting

No Readings or Inaccurate Readings

- Is there power to the WeatherStation Instrument?
- Are all the connections tight?
- Is the cable-run free of kinks?
- Is the wiring correct?
- Are there any obstructions in the wind channel?
*Keep it free of spider webs, insects, dirt, and other debris.
Be careful not to puncture the waterproof film or scratch the reflector plate.*
- Are the temperature and humidity sensors clean?
- Is there ice on the WeatherStation Instrument?

No GPS Fix

- Does the WeatherStation Instrument have a clear view of the sky?

Wind Readings Are Too Low

- Is the WeatherStation Instrument mounted forward and low on the boat/vehicle's hardtop in dead air?
Move the instrument farther back and higher (see Figure 12).

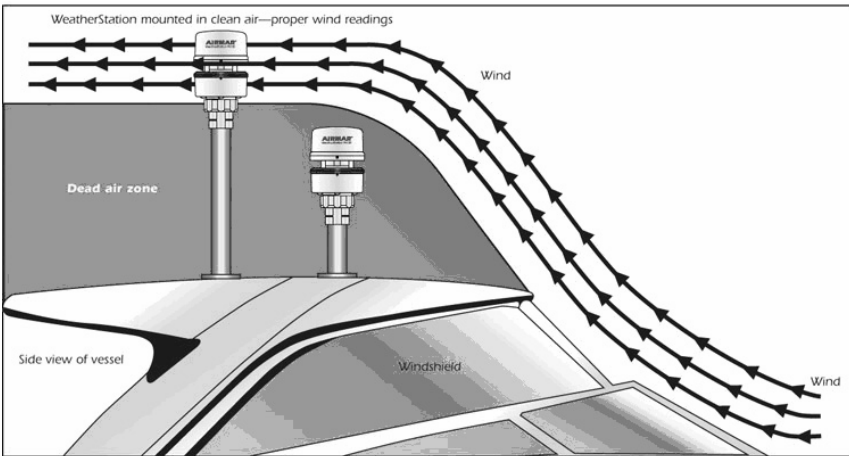

Figure 12. Boat/vehicle mounting location (boat shown)

Copyright © 2007 Airmar Technology Corp.

Rain Sensor Not Working

The rain sensor functions by detecting individual rain drops. To check whether the rain sensor is working, use a gentle spray from a nozzled garden hose. This should produce a reading which indicates that the sensor is active, but the reading will not be calibrated. The sensor is calibrated only for true raindrops falling from a cloud. Do not pour water on the sensor to check whether it is working. The sensor depends on individual drops and will not respond properly to a stream of water.

Technical Information

Additional Data Available from the WeatherStation Instrument

There are parameters that the WeatherStation Instrument can make available to the user. Usually, more data is available from the WeatherStation Instrument than can be displayed in a reasonable format on a screen. Also, if all the data was continuously transmitted to the display, the update rate would be too slow and could not keep up with WeatherStation measurements. Consequently, some parameters are transmitted while others are not, based on a pre-selected list. Note that those parameters not transmitted are, nevertheless, retained in the WeatherStation Instrument. For more detailed information, visit www.airmar.com and go to Installation Instructions and Owner's Guides > WeatherStation Instruments or see the "Technical Manual" on the WeatherCaster CD.

Specification: NMEA 2000®

LEN is the amount of current a device draws from an NMEA 2000 network.
(1 LEN = 50 mA)

NMEA 2000 Load Equivalency Number (LEN)

300WXR.....	NA
300WX.....	4
150WX.....	2
110WX.....	2
PB200.....	13

Acronyms

CD	Compact Disk
EGNOS	European Geostationary Navigation Overlay Service
GPS	Global Positioning System
LEN	Load Equivalency Number
NA	Not Available
NPT	National Pipe Thread
PC	Personal Computer
UNS	Unified National Standard
USB	Universal Serial Bus
WAAS	Wide Area Augmentation System

Glossary

Firmware	The software within the WeatherStation hardware
WeatherCaster™ software	The PC application program

Trademarks

Airmar® is a registered trademark of Airmar Technology Corporation.

NMEA 2000® is a registered trademark of the National Marine Electronics Assoc.

Smart™ Sensor is a trademark of Airmar Technology Corporation.

WeatherCaster™ is a trademark of Airmar Technology Corporation.

WeatherStation® is a trademark of Airmar Technology Corporation.



35 Meadowbrook Drive, Milford, New Hampshire 03055-4613, USA
www.airmar.com