

INSTALLATION INSTRUCTIONS

Threaded-Stem Stuffing Tube

Bronze or Stainless Steel

12/14/10

17-423-01 rev. 04

IMPORTANT: Please read the instructions completely before proceeding with the installation. These instructions supersede any other instructions in your instrument manual if they differ.

Applications

A stuffing tube seals the hull forming a water-tight conduit for the cable.

CAUTION: The stuffing tube must be compatible with the hull material (see table below).

- **Metal hull**—Use a stainless-steel stuffing tube. *Never install a bronze stuffing tube in an aluminum hull because electrolytic corrosion will occur.*
- **Fiberglass hull**—The stuffing tube must be installed in solid fiberglass, *not* in coring.

Hull Material	Stuffing Tube Material	Cable Diameter	Hull Hole Diameter	Airmar Part No.
fiberglass wood	bronze	up to 12mm (0.47")	44mm (1-3/4")	33-511-01
fiberglass wood	stainless steel	up to 12mm (0.47")	44mm (1-3/4")	33-541-01
aluminum steel	stainless steel	up to 12mm (0.47")	50mm (2")	33-541-01

Tools & Materials

- Safety goggles
- Dust mask
- Electric drill with 10mm (3/8") or larger chuck capacity
- Drill bit: 3mm or 1/8"
- Hole saw (see table above)
- Sandpaper
- Mild household detergent *or* weak solvent (such as alcohol)
- File (installation in a metal hull)
- Marine sealant (suitable for below waterline)
- Slip-joint pliers

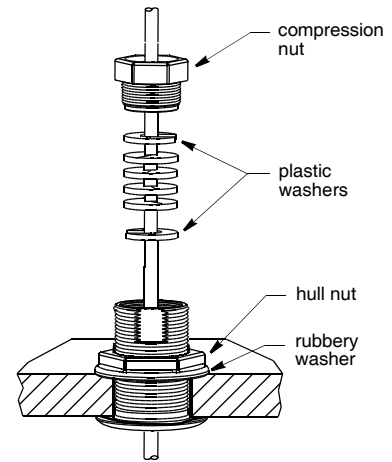

Installing the Stuffing Tube

WARNING: Always wear safety goggles and a dust mask.

WARNING: Metal hull—The stainless-steel stuffing tube must be isolated from the metal hull to prevent electrolytic corrosion.

WARNING: Metal hull—Be sure the washer on the stainless steel stuffing tube contacts the hull. Do not tighten the hull nut with the washer against the isolation bushing as the stuffing tube will not be firmly installed.

1. At the selected mounting location, inspect the hull interior to ensure there is adequate clearance for the stuffing tube and any bolts used to install the transducer. Be sure no cables, ribs, or struts will interfere. Mark the site for the stuffing tube.
2. From inside the hull, drill a 3mm or 1/8" diameter pilot hole perpendicular to the hull. If there is a hull irregularity near the selected mounting location, drill from the outside.
3. Using the appropriate size hole saw, cut a hole from outside the hull *perpendicular* to the hull surface (see table).
4. Sand and clean the area around the hole, inside and outside, to ensure that the marine sealant will adhere properly to the hull. If there is any petroleum residue inside the hull, remove it with either a mild household detergent or a weak solvent (alcohol).
Metal hull—Remove all burrs with a file and sandpaper.
5. Remove the compression nut and hull nut from the stuffing tube.
6. Use marine sealant to seal the hull and hold the hull nut. Apply a 2mm (1/16") thick layer of marine sealant around the flange of the stuffing tube that contacts the hull and up the sidewall of the tube (see Figure 1). The sealant must extend 6mm (1/4") higher than the combined thickness of the hull, rubbery washer, and the hull nut.

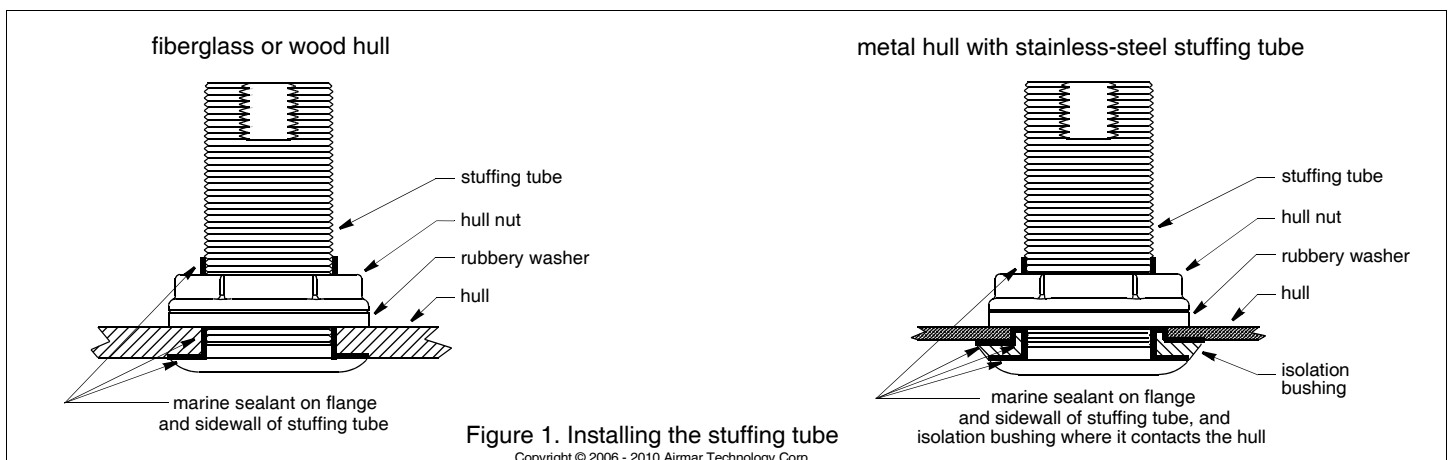

Figure 1. Installing the stuffing tube

Copyright © 2006 - 2010 Airmar Technology Corp.

Metal hull—To isolate the stainless-steel stuffing tube from the metal hull, slide the isolation bushing onto the stuffing tube. Apply *additional* marine sealant to the surfaces of the isolation bushing that will contact the hull, filling any cavities in and around the bushing.

- From outside the hull, push the stem of the stuffing tube through the mounting hole using a twisting motion to squeeze out excess sealant.
- From inside the hull, slide the rubbery washer onto the stuffing tube.

Metal hull—The rubbery washer must contact the hull. *Do not tighten the hull nut with the rubbery washer against the isolation bushing.* The stuffing tube will not be firmly installed. If necessary, sand the isolation bushing until the rubbery washer rests against the hull.

- Screw the hull nut in place. Tighten it with slip-joint pliers.

Wood hull—Allow the wood to swell. *After the hull has expanded, tighten the hull nut securely.*

Installing the Transducer & Fairing

Follow the instructions that came with the transducer and fairing. After they are installed, follow the instructions below to seal the cable inside the stuffing tube.

Sealing the Cable in the Stuffing Tube

WARNING: To form a watertight seal inside the stuffing tube, stagger the splits in the compliant bushings.

- The stuffing tube kit contains two sets of plastic washers. Four are marked 8mm (0.33") diameter and four are marked 12mm (0.47") diameter. Choose the set of plastic washers with the smallest diameter that will fit around your cable. (Discard the other set; it is *not* needed.)
- Put two of the plastic-washer pieces around the cable and press the halves together to form a closed ring (see Figure 2).
- The kit also contains up to four sets of compliant bushings with four bushings in each set. Choose the set of compliant bushings with the smallest diameter that will fit around your cable. (Discard the other sets; they are *not* needed.)
- Place the four compliant bushings around the cable *above* the plastic washer (see Figure 3). Arrange the bushings so that the splits are staggered—*not* aligned. At the top of the stack, press the second pair of plastic washers together to form a closed ring. *Be sure the plastic washers and compliant bushings are stacked as shown in Figure 3.*
- To seal the cable inside the stuffing tube, push the plastic washers and compliant bushings into the stuffing tube forming a tight stack. *Be sure the stack of plastic washers and compliant bushings is seated securely inside the stuffing tube.*
- Screw the compression nut into the stuffing tube until it is snug. Using slip-joint pliers, *tighten the compression nut 2-1/2 turns.* This will compress the compliant bushings slightly to form a watertight seal. **Do not over-tighten.**

Checking for Leaks

WARNING: Do not leave the boat in the water unchecked for several days.

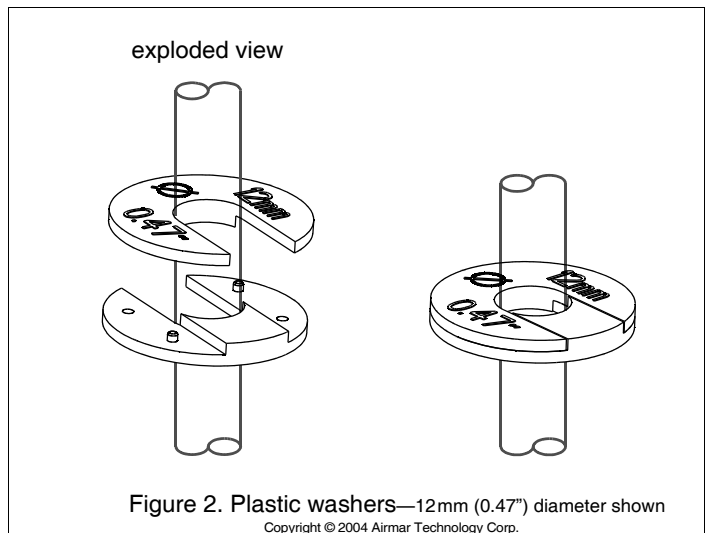

Figure 2. Plastic washers—12 mm (0.47") diameter shown
Copyright © 2004 Airmar Technology Corp.

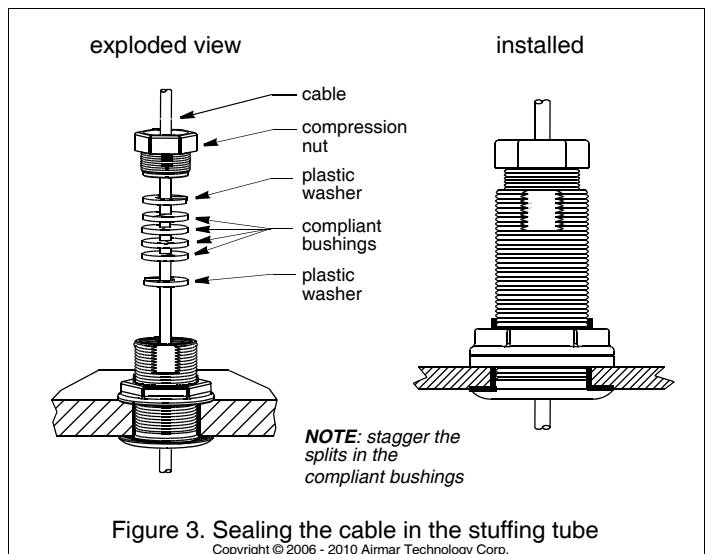

Figure 3. Sealing the cable in the stuffing tube
Copyright © 2006 - 2010 Airmar Technology Corp.

When the boat is placed in the water, **immediately** check around the stuffing tube for leaks. Note that very small leaks may not be readily observed. *Do not* leave the boat in the water unattended for more than 3 hours before checking it again. If there is a small leak, there may be considerable bilge water accumulation after 24 hours. If a leak is observed around the stuffing tube, tighten the compression nut another quarter turn and see if the leakage stops. If the stuffing tube continues to leak, repeat the installation and sealing procedures **immediately**.

Parts

Bronze Stuffing Tube (B165)	33-511-01
Stainless-steel Stuffing Tube (SS571)	33-541-01
Plastic Washers	20-457-01
Compliant Bushings	20-488-01

Obtain parts from your sensor manufacturer or marine dealer.

Gemeco
(USA)
Tel: 803.693.0777
Fax: 803.693.0477
email: sales@gemeco.com

Airmar EMEA
(Europe, Middle East, Africa)
Tel: +33.(0)2.23.52.06.48
Fax: +33.(0)2.23.52.06.49
email: sales@airmar-emea.com

AIRMAR[®]
TECHNOLOGY CORPORATION

35 Meadowbrook Drive, Milford, New Hampshire 03055-4613, USA

■ www.airmar.com

Copyright © 2005 - 2010 Airmar Technology Corp. All rights reserved.