

PB150



Sensing a Change in Your Weather

The enhanced PB150 Ultrasonic WeatherStation® Instrument features higher-accuracy temperature readings and improved wind speed and direction accuracy. WeatherCaster™ PC Software version 2.0 puts your own personal weatherman on-board the boat, 24 hours a day. The easy-to-use program has multiple screen views and advanced setup features to customize what you want to see. No Computer on board—no problem, just connect the PB150 to a NMEA 0183 display* for up-to-the-minute weather information.

Before Leaving the Dock—Decide if you want to spend your day on the water. Anticipate weather fronts by checking the wind speed and direction, temperature, and barometric pressure. Check the weather history graphs, as the WeatherCaster™ Software can store readings for up to 72 hours.

Underway—Monitor up-to-the-minute weather conditions at your location. See where and when the fish will bite best based on wind conditions and a rising or falling barometer.

Docking—The on-board PC or chart plotter can display true wind data to make docking a vessel in high wind a breeze.

Sense a change in your weather with the PB150 Ultrasonic WeatherStation® Instrument.

*NMEA 0183 display must be able to read the specific WeatherStation data sentences.

Ultrasonic WeatherStation® Instrument

Features

- True wind speed and direction
- Apparent wind speed and direction
- Barometric pressure
- Air temperature
- Wind chill temperature
- Measures wind speed and direction ultrasonically
- Internal WAAS/EGNOS GPS
- Two-axis solid-state compass
- Three-axis accelerometer provides pitch and roll
- Plastic housing is less prone to lightning strikes
- NMEA 0183 output
- WeatherCaster™ Software
- 360° calibration results in precise wind direction accuracy
- Very easy installation and two-year warranty
- Maintenance-free operation—no moving parts
- Recommended for recreational powerboats



Sensing Technology



www.airmar.com



Technical Information

SPECIFICATIONS

- Wind Speed Range:** 0 knots to 80 knots (0 MPH to 92 MPH)
- Wind Speed Resolution:** 0.1 knots (0.1 MPH)
- Wind Speed Accuracy @ 0°C to 55°C (32°F to 131°F), no precipitation*:**
 — Low Wind Speeds: 0 knots to 10 knots (0 MPH to 11.5 MPH); RMS error of 1 knot (± 1.1 MPH) +10% of reading
 — High Wind Speeds: 10 knots to 80 knots (11.5 MPH to 92 MPH); RMS error of 2 knots (± 2.3 MPH) or 5% RMS, whichever is greater
- Wind Speed Accuracy in wet conditions**:** 5 knots (5.7 MPH) RMS
- Wind Direction Range:** 0° to 360°
- Wind Direction Resolution:** 0.1°
- Wind Direction Accuracy @ 0°C to 55°C (32°F to 131°F), no precipitation*:**
 — Low Wind Speeds: 4 knots to 10 knots (4.6 MPH to 11.5 MPH)—5° RMS typical
 — High Wind Speeds: >10 knots (>11.5 MPH)—2° RMS typical
- Wind Direction Accuracy in wet conditions**:**
 >8 knots (>9.2 MPH)—8° RMS typical
- Compass Accuracy:** 1° RMS when level
- Pitch and Roll Range / Accuracy:** $\pm 50^\circ$ / $< 1^\circ$ static tested @ 25°C (77°F)
- Air Temperature Range:** -25°C to 55°C (-13°F to 131°F)
- Air Temperature Resolution:** 0.1°C (0.1°F)
- Air Temperature Accuracy:** $\pm 1^\circ\text{C}$ ($\pm 1.8^\circ\text{F}$)* @ >4 knots (>4.6 MPH) wind
- Barometric Pressure Range:**
 850 mbar to 1150 mbar (25 inHg to 34 inHg, 850 hPa to 1150 hPa)
- Barometric Pressure Resolution:** 0.1 mbar (0.029 inHg, 0.1 hPa)
- Barometric Pressure Accuracy:**
 ± 2 mbar (± 0.059 inHg, ± 2 hPa) when altitude correction is available
- GPS Position Accuracy:**
 3 m (10') with WAAS/EGNOS (95% of the time, SA off)
- Operating Temperature Range:** -25°C to 55°C (-13°F to 131°F)
- Supply Voltage:** 9 VDC to 16 VDC
- Supply Current:** <150 mA
- Weight:** 285 grams (0.7 lb)
- Sensor Baud Rate (NMEA 0183 Interface Only):**
 4,800 bps (can be increased to 38,400 bps with a command)
- Thread Sizes on Base:** 1"-14 UNS standard marine mount
- Certifications and Standards:** CE, RoHS

RMS—Root Mean Square

*When the wind speed is less than 4 knots (4.6 MPH) and/or air temperature is below 0°C (32°F), wind and temperature readings will be less accurate.

**Wet conditions include moisture, rain, frost, dew, snow, ice and/or sea spray in the wind channel.

State-of-the-Art Wind Tunnel—Airmar's on-site wind tunnel is calibrated with a pitot tube, which in turn was calibrated with a National Institute of Standards and Technology (NIST) traceable pitot tube.

DATA OUTPUT PROTOCOL

- NMEA 0183 Sentence Structure**
- \$GPDTMDatum Reference
 - \$GPGGAGPS Fix Data
 - \$GPGLL Geographic Position—Latitude and Longitude
 - \$GPGSAGNSS DOP and Active Satellite
 - \$GPGSVSatellites in View
 - \$GPRMCRecommended Minimum GNSS
 - \$GPVTGCOG and SOG
 - \$GPZDATime and Date
 - \$HCHDGHeading, Deviation, and Variation
 - \$WIMDAMeteorological Composite
 - \$WIMWD ...Wind Direction and Speed
 - \$WIMWV ...Wind Speed and Angle
 - \$WIMWR ...Relative Wind Direction and Speed
 - \$WIMWT ...True Wind Direction and Speed
 - \$YXXDRTransducer Measurements

DIMENSIONS

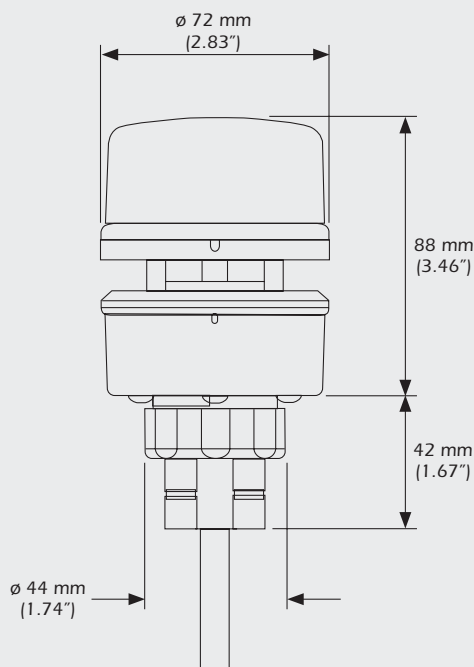

▪ Standard 1"-14 standard marine mount connection accommodates existing mounting hardware.