

B260 SS260



Powerful, Yet Sensitive!

The B260 will enhance fish detection on virtually all of today's fish finders. High-performance has been redefined with its Broadband Ceramic Technology. The narrow, 6° beam 200 kHz ceramic will give you excellent resolution and crisp image detail needed for bottom fishing. The B260's low ringing is perfect for finding fish holding tight to the bottom and other structure. The seven-element 50 kHz array has a wider 19° beam for deeper blue-water fishing. The outcome at both frequencies is excellent resolution and crisp image detail where it's needed most.

Streamlined Performance

This best seller is offered in both bronze and stainless steel housings. Get maximum results, on any hull material, when installed with a custom-fitting High-Performance Fairing. At speeds over 30 knots (34 MPH), screens continue to display clear images and solid bottom tracking.

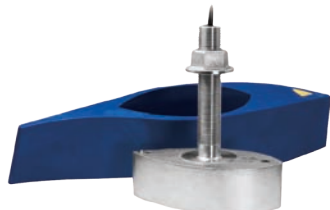

Stainless steel housing—SS260

1 kW, High-Definition Digital Broadband

Thru-Hull Transducer

Fishing Applications

- Blue-water trolling using 50 kHz
- Deep-water bottom and wreck fishing up to 800 m (2,625')

Features

- Top-of-the-line 1 kW thru-hull model
- Depth and new fast-response water-temperature sensor
- Recommended for sportfishing boats above 9 m (30') and small to mid-size commercial fishing boats
- Available with a diplexer for single-transmission-line fishfinders and without a diplexer for dual-transmission-line fishfinders
- Bronze or stainless steel housings available
- Interfaces to any 600 W or 1 kW echosounder



Sensing Technology

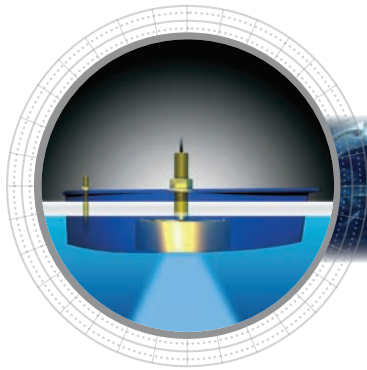

www.airmar.com



B260, SS260

Technical Information

50 kHz-AE / 200 kHz-BH

Number of Elements and Configuration		
Beamwidth (@-3 dB)	19°	6°
RMS Power (W)	1 kW	1 kW
TVR	162 dB	175 dB
RVR	-173 dB	-183 dB
FOM	-14	-10
Q	8	8
Impedance	250 Ω	90 Ω

MAXIMUM DEPTH RANGE

50 kHz	200 kHz
529 m to 735 m (1,800' to 2,500')	206 m to 294 m (700' to 1,000')

BEAM DIAMETER VS DEPTH

Depth	50 kHz	200 kHz
9 m (30')	3 m (10')	0.9 m (3')
30 m (100')	10 m (34')	3.3 m (11')
122 m (400')	41 m (134')	13 m (42')
305 m (1,000')	102 m (335')	32 m (105')

TRANSDUCER COMPARISON

Model	Power	Rating	Performance Increase
B45 B744V B744VL	600 W	Good	Benchmark model for comparison
B258	1 kW	Better	25 times more sensitive at 50 kHz 16 times more sensitive at 200 kHz
B260 SS260	1 kW	Best	50 times more sensitive at 50 kHz 13 times more sensitive at 200 kHz
R99	2 kW	Superb	200 times more sensitive at 50 kHz 32 times more sensitive at 200 kHz
R209 R309	3 kW	Ultimate	400 times more sensitive at 50 kHz 32 times more sensitive at 200 kHz

Due to the wide beam of the SS270W, it has been omitted from the table.

SPECIFICATIONS

Weight: 7.3 kg (16 lb)
Hull Deadrise: Up to 20° with fairing
Acoustic Window: Urethane

DIMENSIONS

Transducer and High-Performance Fairing

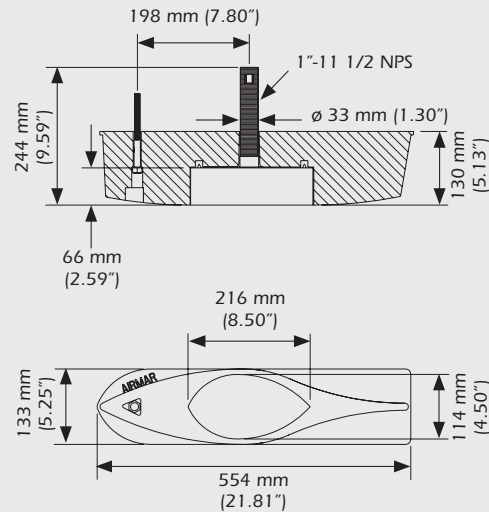

B260, SS260 Transducer

