

CS4500

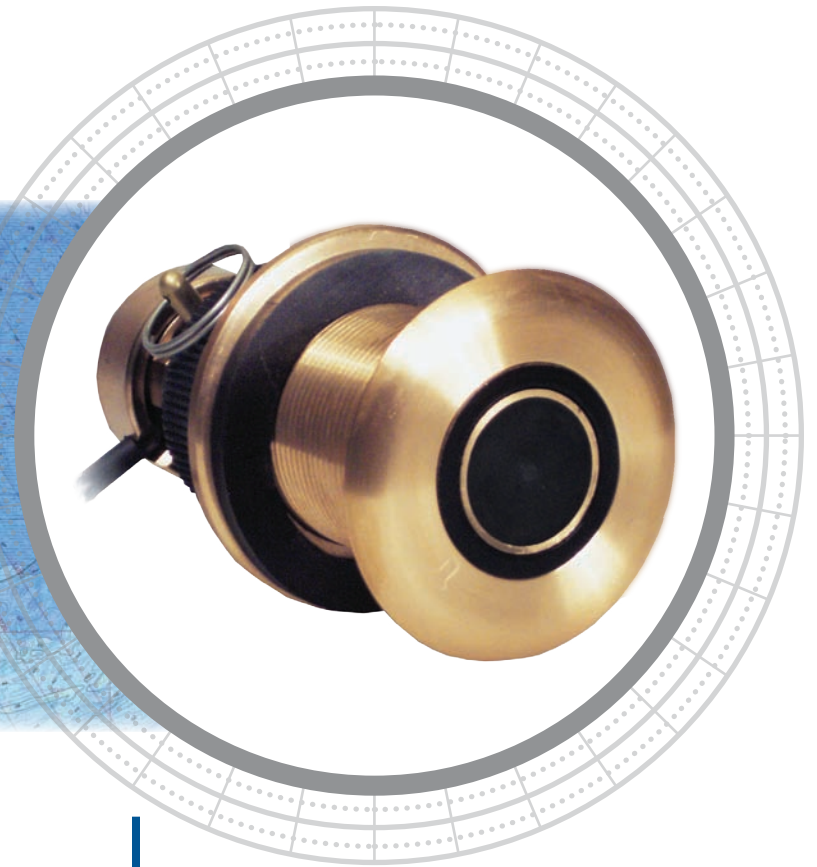

High-Precision, Low Maintenance

Innovation at its finest! If one consistently demands the best, Airmar's CS4500 Ultrasonic Speed Sensor delivers.

Ultra-accuracy is foremost! With no moving parts, the ultrasonic sensor is capable of speed reading accuracy as low as 0.1 knots (0.1 MPH). By eliminating the traditional paddlewheel, there is no fouling, and drag is reduced to a minimum. Unlike paddlewheels, the CS4500 is engineered to measure water speed below the turbulent boundary layer of the hull, resulting in accurate clean-water readings.

Tried and True Technology

The innovation doesn't stop here. Ultrasonic sensing is a proven technology that has been used on ships for nearly 20 years. Building on this technology, Airmar developed an advanced design which operates at a higher-frequency, enabling reliable operation in both salt and fresh water. The state-of-the-art processor in the CS4500 calculates speed every half second, so it can respond to rapid changes in vessel speed. This translates into the most reliable and accurate ultrasonic speed sensor on the market—at a very competitive price.

Speed Sensor

Ultrasonic—No Moving Parts
Thru-Hull Transducer

Features

- Unparalleled accuracy as low as 0.1 knots (0.1 MPH)
- Designed for use with all types and sizes of sailboats and powerboats
- No moving parts
- Makes retrofitting a breeze—the retractable insert fits most Airmar 51 mm (2") housings
- Low-profile, plastic, or bronze housings available
- Built-in temperature sensor
- Optional Data Converter charges analog signal to NMEA 0183 data stream



Sensing Technology

www.airmar.com

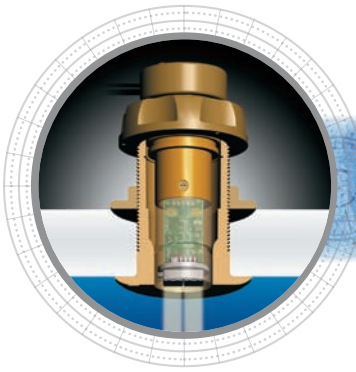

Technical Information

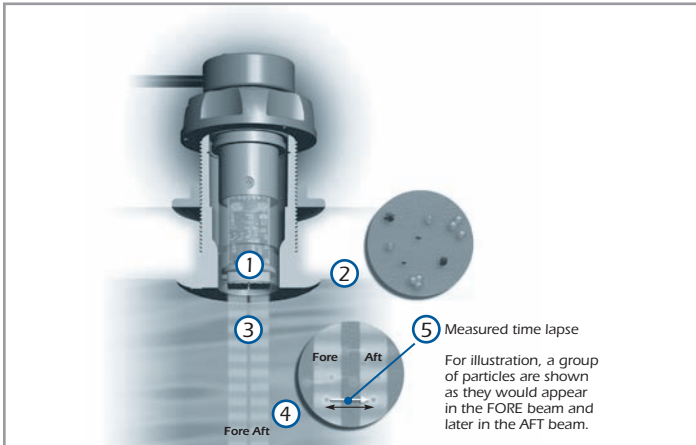

How the CS4500 Works

- 1** In the CS4500, two transducers are incorporated in a single housing.
- 2** Small particles present in the water pass through the beam.
- 3** The speed sensor uses ultrasonic pulses to collect echoes from the small particles in the water as they pass under two ceramics embedded in the sensor.
- 4** As the boat travels through the water, both ceramics "view" the same stream of particles.
Because it takes time for particles to travel between the two ceramics, the aft ceramic detects the particles later than does the fore ceramic.
- 5** By measuring this time lapse, the instrument is able to calculate the boat speed.

SPECIFICATIONS

Weight:
 —1.4 kg (3 lb)—Plastic
 —1.8 kg (4 lb)—Bronze

Speed Measured:
 77 mm to 178 mm (3" to 5") below the hull (outside the boundary layer)

Frequency: 4.5 MHz

Pulse Repetition Frequency: 5.5 kHz

Signal Output: Airmar paddlewheel format

Data Update Rate: 2 seconds

Speed Range: 0.1 knot to 40 knots (0.1 MPH to 46 MPH)

Operating Temperature Range: 0°C to 40°C (32°F to 104°F)

Sensor Insert Material: Bronze

Thru-Hull Housing Material: Plastic or bronze

Sensor Cable Type: Airmar C190

Sensor Cable Length: 10 m (33') standard

Instrument Cable Length: 3 m (10') standard, up to 30 m (10') possible

Blanking Plug: Yes

Supply Voltage: 10 VDC to 15 VDC

Supply Current: 155 mA at 12 VDC

Hole Diameter: 51 mm (2")

CE Compliant: Yes

DIMENSIONS

P17 Plastic and B17 Bronze

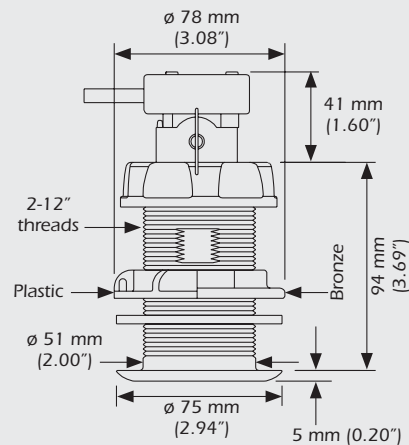

P120 Plastic and B120 Bronze

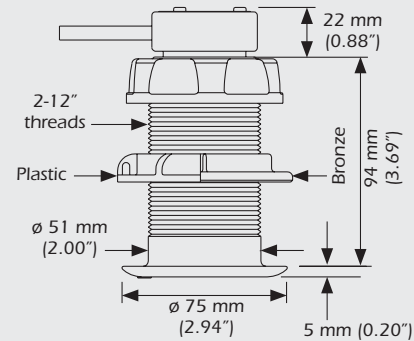

▪ Also available in P314/B21 and P217/B119 housings